



ADTECH
Analog-Digital Technology, Inc.

200 Series Two-Wire Field Selectable Wide Ranging Transmitters Guide



Features

- **Types of Inputs:** AC I/V (TRMS or average); frequency, millivolts, potentiometer, RTD, DC I/V, T/C.
- **No Interaction:** Zero and span controls
- **Elevation/Suppression:** Up to 100% of range
- **Power Range:** 8 to 42 VDC
- **RFI-Resistant**
- **Temperature Coefficients:**
Zero = $\pm 0.007\%/^{\circ}\text{C}$ of span—typical
Span = $\pm 0.008\%/^{\circ}\text{C}$ of span—typical
- **Repeatability:** $\pm 0.002\%$ typical
- **Bandwidth:** (-3 db): 3.2 Hz typical
- **Isolation:** 1000 VDC or 600 VAC
- **Power Supply Effect:** $\pm 0.005\%$ of span
- **Response Time:** 110 milliseconds typical
- **Reverse Polarity Protection**

Typical Applications

Measurement of:

- Temperature
- Flow
- Speed
- Position
- Displacement
- Rotation
- AC Current
- AC Voltage
- DC Signals

AC Input ACX 240 (Isolated)

Input/Output

Input Signals

AC Current: Any 0-1 to 0-5 amps AC, burden less than 0.5 VA (Selectable average or true RMS responding)

AC Voltage: Any 0-0.25 to 0-250 VAC, burden less than 0.5 VA (Selectable average or true RMS responding) (4 major ranges 0.25, 2.5, 25, 250)

Zero Adjustment: ±5% nominal of span

Course Span Adjustment: 100% of a major range (voltage only)

Fine Span Adjustment: ±5% nominal of major range (±1 Amp for current input)

Input Frequency Range: 25-1,000 Hz

Input Overload Capability: 200% continuous

Output Signal: 4-20 mA DC

Output Loop Drive Capability:

$$R(\text{ohm}) = \frac{(V \text{ supply} - V \text{ minimum})1,000}{I \text{ out max. mA}}$$

V minimum= 8.0 VDC

I out	4-20 mA			
V supply	12	24	36	42
R(ohms)	200	800	1400	1700

Performance

Calibrated Accuracy: ±0.25%

Independent Linearity: ±0.15% maximum, ±0.06% typical

Repeatability: ±0.005% max., ±0.002% typ.

Zero TC: ±0.01% of span max/°C

Span TC: +0.02% of span max/°C

Load Effect: ±0.005% zero to full load

Output Ripple: 10 mV P/P maximum

Response Time: 350 milliseconds (10 to 90% step response) average responding

Bandwidth: (-3 db): 1 Hz

Temperature Range:

-25° to 185°F (-31° to 85°C) operating;

-40° to 200°F (-40° to 93°C) storage

Power Supply Effect: ±0.005% of span, max.

Isolation: Input/output/case: 1000 VDC or 600 VAC

Note: All accuracies are given as a % of span.

Power

8 to 42 VDC: Standard

Mechanical

Electrical Classification: General purpose

Connection: Screw, compression type, accepts up to 14 AWG

Controls: One 16-position rotary switch for course span; two multiturn potentiometers for fine zero and span control, jumpers for measurement response type TRMS or average and for input ranges

Mounting: DIN rails, Surface, snap-track, or NEMA 4 or 7

Weight: Net Unit: 4 oz. (115 grams);

Shipping: Nominal 7 oz. (200 grams)

Options

H 15 D, H 25 – H 30 Mounting
LPI 40 D Loop powered indicator

Frequency Input FDX 250 (Isolated)

Input/Output

Input Signals

Voltage (Amplitude): 10 mV-100 Vrms (0-5 kHz); 50 mV to 50 Vrms (5 kHz to 30 kHz)

Contact: Dry, 2 mA @ 24 VAC rating

Frequency Range: 0-30 Hz to 0-30 kHz full scale

Major Range Switch: Provides 11 discrete ranges with the zero control adjustable 10% of output and span control adjustable from 50% to 100% of the major range selected

Output Signal: 4-20 mA DC

Output Loop Drive Capability:

$$R(\text{ohm}) = \frac{(V \text{ supply} - V \text{ minimum})1,000}{I \text{ out max. mA}}$$

V minimum= 8.0 VDC

I out	4-20 mA			
V supply	12	24	36	42
R(ohms)	200	800	1400	1700

Performance

Calibrated Accuracy: ±0.1%

Independent Linearity: ±0.02% max.; ±0.01% typical

Repeatability: ±0.005% max., ±0.002% typ.

Zero TC: ±0.01% of span max/°C

Span TC: ±0.01% of span max/°C

Load Effect: ±0.005% zero to full load

Output Ripple: 10 mV P/P maximum

Response Time: 350 milliseconds (10 to 90% step response)

Bandwidth: (-3 db): 1 Hz

Temperature Range:

-25° to 185°F (-31° to 85°C) operating;

-40° to 200°F (-40° to 93°C) storage

Power Supply Effect: ±0.005% of span, max.

Isolation: Input/output/case: 1000 VDC or 600 VAC

Note: All accuracies are given as a % of span.

Power

8 to 42 VDC: Standard

Mechanical

Electrical Classification: General purpose

Connection: Screw, compression type, accepts up to 14 AWG

Controls: One 16 position rotary switch for major range; four multiturn potentiometers for zero, span, hysteresis and sensitivity

Mounting: DIN rails, Surface, snap-track, or NEMA 4 or 7

Weight: Net Unit: 4 oz. (115 grams);

Shipping: Nominal 7 oz. (200 grams)

Options

H 15 D, H 25 – H 30 Mounting
LPI 40 D Loop powered indicator

MV Input MVX 206 (Non-Isolated)

Input/Output

Input Signals

0.5 mV to 100 mV span (Z in greater than 10 megohms)

Zero Suppression: Up to 100% of the major range selected in 16 divisions of the coarse zero adjustment switch

Span: From 0.5 mV to 100 mV full scale switch selectable. The coarse span switch adds 16 divisions to each major range.

Output Signal: 4-20 mA DC

Output Loop Drive Capability:

$$R(\text{ohm}) = \frac{(V \text{ supply} - V \text{ minimum})1,000}{I \text{ out max. mA}}$$

V minimum= 8.0 VDC

I out	4-20 mA			
V supply	12	24	36	42
R(ohms)	200	800	1400	1700

Performance

Calibrated Accuracy: ±0.1%

Independent Linearity: ±0.01% maximum, ±0.006% typical (14-bit digital linearity)

Repeatability: ±0.005% max., ±0.002% typ.

Zero TC: $\pm \left(\frac{0.025}{\text{input span (mV)} + 0.005} \right)$ % of span max./°C

Span TC: ±0.008% of span max/°C

Load Effect: ±0.005% zero to full load

Output Ripple: 10 mV P/P maximum

Response Time: 110 milliseconds (10 to 90% step response)

Bandwidth: (-3 db): 3.2 Hz

Temperature Range:

-25° to 185°F (-31° to 85°C) operating;

-40° to 200°F (-40° to 93°C) storage

Power Supply Effect: ±0.005% of span, max.

Note: All accuracies are given as a % of span.

Power

8 to 42 VDC: Standard

Mechanical

Electrical Classification: General purpose

Connection: Screw, compression type, accepts up to 14 AWG

Controls: Two 16 position rotary switches for coarse zero and span control; two multiturn potentiometers for fine zero, and span control and jumpers for major range and zero elevation

Mounting: DIN rails, Surface, snap-track, or NEMA 4 or 7

Weight: Net Unit: 4 oz. (115 grams);

Shipping: Nominal 7 oz. (200 grams)

Options

H 15 D, H 25 – H 30 Mounting
LPI 40 D Loop powered indicator

MV Input MVX 226 (Isolated)

Input/Output

Input Signals

0.5 mV to 100 mV span (Z in greater than 10 megohms)

Zero Suppression: Up to 100% of the major range selected in 16 divisions of the coarse zero adjustment switch

Span: From 0.5 mV to 100 mV full scale switch selectable. The coarse span switch adds 16 divisions to each major range.

Output Signal: 4-20 mA DC

Output Loop Drive Capability

$$R(\text{ohm}) = \frac{(V \text{ supply} - V \text{ minimum})1,000}{I \text{ out max. mA}}$$

$$V \text{ minimum} = 8.0 \text{ VDC}$$

I out	4-20 mA			
V supply	12	24	36	42
R(ohms)	200	800	1400	1700

Performance

Calibrated Accuracy: ±0.1%

Independent Linearity: ±0.01% maximum, ±0.006% typical (14-bit digital linearity)

Repeatability: ±0.005% max., ±0.002% typ.

$$\text{Zero TC: } \pm \left(\frac{0.025}{\text{input span (mV)}} + 0.005 \right) \% \text{ of span max./}^\circ\text{C}$$

Span TC: ±0.008% of span max/°C

Load Effect: ±0.005% zero to full load

Output Ripple: 10 mV P/P maximum

Response Time: 110 milliseconds (10 to 90% step response)

Bandwidth: (-3 db): 3.2 Hz

Temperature Range:

-25° to 185°F (-31° to 85°C) operating;

-40° to 200°F (-40° to 93°C) storage

Power Supply Effect: ±0.005% of span, max.

Isolation: Input/output/case: 1000 VDC, or 600 VAC

Note: All accuracies are given as a % of span.

Power

8 to 42 VDC: Standard

Mechanical

Electrical Classification: General purpose

Connection: Screw, compression type, accepts up to 14 AWG

Controls: Two 16 position rotary switches for coarse zero and span control; two multiturn potentiometers for fine zero, and span control and jumpers for major range and zero elevation

Mounting: DIN rails, Surface, snap-track, or NEMA 4 or 7

Weight: Net Unit: 4 oz. (115 grams);

Shipping: Nominal 7 oz. (200 grams)

Options

H 15 D, H 25 – H 30 Mounting
I 14 Voltage/current inputs
LPI 40 D Loop powered indicator

Potentiometer Input PTX 273 (Non-Isolated)

Input/Output

Input Signals

Potentiometers/Slidewire Sensors: 3 Wire
50 ohm to 100 k ohm Resistance Spans
Standard

Zero Suppression: Up to 100% of the potentiometer rotation selected in 16 divisions of the coarse zero adjustment switch.

Span: From 0-100% full scale switch selectable. The coarse span switch adds 16 range divisions.

Output Signal: 4-20 mA DC

Output Loop Drive Capability

$$R(\text{ohm}) = \frac{(V \text{ supply} - V \text{ minimum})1,000}{I \text{ out max. mA}}$$

$$V \text{ minimum} = 8.0 \text{ VDC}$$

I out	4-20 mA			
V supply	12	24	36	42
R(ohms)	200	800	1400	1700

Performance

Calibrated Accuracy: ±0.1%

Independent Linearity: ±0.01% maximum, ±0.006% typical (14-bit digital linearity)

Repeatability: ±0.005% max., ±0.002% typ.

Zero TC: ±0.007% of span max/°C

Span TC: ±0.010% of span max/°C

Load Effect: ±0.005% zero to full load

Output Ripple: 10 mV P/P maximum

Response Time: 110 milliseconds (10 to 90% step response)

Bandwidth: (-3 db): 3.2 Hz

Temperature Range:

-25° to 185°F (-31° to 85°C) operating;

-40° to 200°F (-40° to 93°C) storage

Power Supply Effect: ±0.005% of span, max.

Note: All accuracies are given as a % of span.

Power

8 to 42 VDC: Standard

Mechanical

Electrical Classification: General purpose

Connection: Screw, compression type, accepts up to 14 AWG

Controls: Two 16 position rotary switches for coarse zero and span control; two multiturn potentiometers for fine zero, and span control

Mounting: DIN rails, Surface, snap-track, or NEMA 4 or 7

Weight: Net Unit: 4 oz. (115 grams);

Shipping: Nominal 7 oz. (200 grams)

Options

H 15 D, H 25 – H 30 Mounting
LPI 40 D Loop powered indicator

RTD Input RBX 274 (Non-Isolated)

Input/Output

Input Signals

Resistance Bulb Sensor: 2,3, or 4 wire types

1 to 400 ohm Resistance Spans: Standard

Zero Suppression: Up to 100% of the major range selected in 16 divisions of the coarse zero adjustment switch.

Span: From 0-100% full scale switch selectable. The coarse span switch adds 16 divisions to each major range.

Lead Compensation: 1% maximum error, of differential lead resistance.

Output Signal: 4-20 mA DC

Output Loop Drive Capability:

$$R(\text{ohm}) = \frac{(V \text{ supply} - V \text{ minimum}) 1,000}{I \text{ out max. mA}}$$

$$V \text{ minimum} = 8.0 \text{ VDC}$$

I out	4-20 mA			
V supply	12	24	36	42
R(ohms)	200	800	1400	1700

Performance

Calibrated Accuracy: ±0.1%

Independent Linearity: ±0.025% max., ±0.01% typical

Conformance to RTD Curves: 0.15% max.

Repeatability: ±0.005% max., ±0.002% typ.

$$\text{Zero TC: } \pm \left(\frac{0.05}{\text{input span (ohms)}} + 0.005 \right) \% \text{ of span/}^\circ\text{C max.}$$

Span TC: ±0.008% of span max./°C

Load Effect: ±0.005% zero to full load

Output Ripple: 10 mV P/P maximum

Response Time: 110 milliseconds (10 to 90% step response)

Bandwidth: (-3 db): 3.2 Hz

Temperature Range:

-25° to 185°F (-31° to 85°C) operating;

-40° to 200°F (-40° to 93°C) storage

Power Supply Effect: ±0.005% of span, max.

Note: All accuracies are given as a % of span.

Power

8 to 42 VDC: Standard

Mechanical

Electrical Classification: General purpose

Connection: Screw, compression type, accepts up to 14 AWG

Controls: Two 16 position rotary switches for coarse zero and span control; two multiturn potentiometers for fine zero, and span control and jumpers for RTD type, major range and input zero elevation

Mounting: DIN rails, Surface, snap-track, or NEMA 4 or 7

Weight: Net Unit: 4 oz. (115 grams);

Shipping: Nominal 7 oz. (200 grams)

Options

H 15 D, H 25 – H 30 Mounting
LPI 40 D Loop powered indicator

RTD Input RBX 272 (Isolated)

Input/Output

Input Signals

Resistance Bulb Sensor: 2,3, or 4 wire types
1 to 400 ohm Resistance Spans: Standard
Zero Suppression: Up to 100% of the major range selected in 16 divisions of the coarse zero adjustment switch.
Span: From 0-100% full scale switch selectable. The coarse span switch adds 16 divisions to each major range.
Lead Compensation: 1% maximum error, of differential lead resistance.

Output Signal: 4-20 mA DC
Output Loop Drive Capability:

$$R(\text{ohm}) = \frac{(V \text{ supply} - V \text{ minimum}) 1,000}{I \text{ out max. mA}}$$

V minimum= 8.0 VDC

I out	4-20 mA			
V supply	12	24	36	42
R(ohms)	200	800	1400	1700

Performance

Calibrated Accuracy: ±0.1%
Independent Linearity: ±0.025% max., ±0.01% typical
Conformance to RTD Curves: 0.15% max.
Repeatability: ±0.005% max., ±0.002% typ.
Zero TC: $\pm \left(\frac{0.05}{\text{input span (ohms)}} + 0.005 \right)$ % of span/°C max.
Span TC: ±0.008% of span max./°C
Load Effect: ±0.005% zero to full load
Output Ripple: 10 mV P/P maximum
Response Time: 110 milliseconds (10 to 90% step response)
Bandwidth: (-3 db): 3.2 Hz
Temperature Range:
 -25° to 185°F (-31° to 85°C) operating;
 -40° to 200°F (-40° to 93°C) storage
Power Supply Effect: ±0.005% of span, max.
Isolation: Input/output/case: 1000VDC, or 600 VAC
Note: All accuracies are given as a % of span.

Power

8 to 42 VDC: Standard

Mechanical

Electrical Classification: General purpose
Connection: Screw, compression type, accepts up to 14 AWG
Controls: Two 16 position rotary switches for coarse zero and span control; two multiturn potentiometers for fine zero and span control and jumpers for RTD type; major range and input zero elevation
Mounting: DIN rails, Surface, snap-track, or NEMA 4 or 7
Weight: Net Unit: 4 oz. (115 grams);
Shipping: Nominal 7 oz. (200 grams)

Options

H 15 D, H 25 – H 30 Mounting
LPI 40 D Loop powered indicator

I/V/MV Input SCX 202 (Isolated)

Input/Output

Input Signals

4-20 mA DC (z in 10 ohms)
0-20 or ± 20 mA DC (z in 10 ohms)
0-10 or ±10 mA DC (z in 20 ohms)
0-1 or ±1 mA DC (z in 200 ohms)
1-5 VDC (z in 1 megohm)
0-5 or ±5 VDC (z in 1 megohm)
0-10 or ±10 VDC (z in 1 megohm)
 Any unipolar or bipolar voltage from 100 MV to 200 VDC. (Option I 14)
Zero Suppression: ±10%
Span Adjustment: ±10%

Output Signal: 4-20 mA DC
Output Loop Drive Capability:

$$R(\text{ohm}) = \frac{(V \text{ supply} - V \text{ minimum}) 1,000}{I \text{ out max. mA}}$$

V minimum= 8.0 VDC

I out	4-20 mA			
V supply	12	24	36	42
R(ohms)	200	800	1400	1700

Performance

Calibrated Accuracy: ±0.1%
Independent Linearity: ±0.025% max., ±0.01% typical
Repeatability: ±0.005% max., ±0.002% typ.
Zero TC: ±0.007% of span max./°C
Span TC: ±0.008% of span max./°C
Load Effect: ±0.005% zero to full load
Output Ripple: 10 mV P/P maximum
Response Time: 110 milliseconds (10 to 90% step response)
Bandwidth: (-3 db): 3.2 Hz
Temperature Range:
 -25° to 185°F (-31° to 85°C) operating;
 -40° to 200°F (-40° to 93°C) storage
Power Supply Effect: ±0.005% of span, max.
Isolation: Input/output/case: 1000 VDC or 600 VAC
Note: All accuracies are given as a % of span.

Power

8 to 42 VDC: Standard

Mechanical

Electrical Classification: General purpose
Connection: Screw, compression type, accepts up to 14 AWG
Controls: Two multiturn potentiometers for Zero Span control; jumpers for ranges
Mounting: DIN rails, Surface, snap-track, or NEMA 4 or 7
Weight: Net Unit: 4 oz. (115 grams);
Shipping: Nominal 7 oz. (200 grams)

Options

H 15 D, H 25 – H 30 Mounting
I 14 Voltage/current inputs
LPI 40 D Loop powered indicator

T/C Input TCX 226 (Isolated)

Input/Output

Input Signals

***Thermocouple:** All standard ISA calibration (B, E, J, K, R, S, T), -20 mV to 100 mV spans (Z in greater than 1 megohm)
Zero Suppression: Up to 100% of the major range selected in 16 divisions of the coarse zero adjustment switch.
Span: From 0.5 mV to 100 mV full scale switch selectable. The coarse span switch adds 16 divisions to each major range.
Upscale/Downscale Burnout Protection: Standard, field selectable
Burnout Current: 0.1 micro amperes—nominal
**Consult factory for other T/C types.*

Output Signal: 4-20 mA DC
Output Loop Drive Capability:

$$R(\text{ohm}) = \frac{(V \text{ supply} - V \text{ minimum}) 1,000}{I \text{ out max. mA}}$$

V minimum= 8.0 VDC

I out	4-20 mA			
V supply	12	24	36	42
R(ohms)	200	800	1400	1700

Performance

Calibrated Accuracy: ±0.1% (of mv input)
Independent Linearity: ±0.01% max., ±0.006% typical (14-bit digital linearity) (of millivolt input)
Repeatability: ±0.005% max., ±0.002% typ.
Zero TC: $\pm \left(\frac{0.025}{\text{input span (MV)}} + 0.007 \right)$ % of span/°C max.
Span TC: ±0.008% of span max./°C
Load Effect: ±0.005% zero to full load
Output Ripple: 10 mV P/P maximum
Response Time: 110 milliseconds (10 to 90% step response)
Bandwidth: (-3 db): 3.2 Hz
Temperature Range:
 -25° to 185°F (-31° to 85°C) operating;
 -40° to 200°F (-40° to 93°C) storage
Power Supply Effect: ±0.005% of span, max.
Isolation: Input/output/case, 1000 VDC, or 600 VAC
Cold Junction Compensation Error: 1.5°C max (0 to 50°C)
Note: All accuracies are given as a % of span.

Power

8 to 42 VDC: Standard

Mechanical

Electrical Classification: General purpose
Connection: Screw, compression type, accepts up to 14 AWG
Controls: Two 16 position rotary switches for coarse zero and span control; two multiturn potentiometers for fine zero and span control and jumpers for T/C type, major range and input zero elevation
Mounting: DIN rails, Surface, snap-track, or NEMA 4 or 7
Weight: Net Unit: 4 oz. (115 grams);
Shipping: Nominal 7 oz. (200 grams)

Options

H 15 D, H 25 – H 30 Mounting
LPI 40 D Loop powered indicator

The ADTECH 200 Series Two-Wire Transmitters provide field mounted efficiency and ease of wiring in a compact DIN package. The units convert sensor inputs to the industry standard 4-20 mA DC Two-Wire loop output for interface directly with PLC's, DCS's and process computers.

Most units provide independent linearity equivalent to 14-bit digital accuracy and include user friendly features such as wide ranging and non-interactive zero and span controls.

The compact DIN mounting style allows high density mounting in new or existing field mounted or control panel enclosures.

Standard mounting is DIN Rail. Surface or snap track mounting is provided at no charge. NEMA 4 or 7 are optionally available.

These units are designed for industrial environments. The housing is made of rugged Krilen for protection against corrosion, moisture and dust.

Screw compression terminals are provided for positive field connections.

Reverse polarity protection and current limiting are supplied as standard.

The power range of 8 to 42 VDC provides valuable added drive capability.

The input can be factory set to order as specified (no charge) or reconfigured in the field by simply adjusting switches, multi-turn potentiometers, and plug-in jumpers.

Integral LCD field indicator (LPI 40D) is optionally available.

AC to DC or DC to DC instrument power supplies are available. The IPS 2402 AC/DC powers up to 2 units. The IPS 2416 AC/DC or DC/DC powers up to 16 units. DIN, surface, snap track or NEMA mountings are available.

Connections

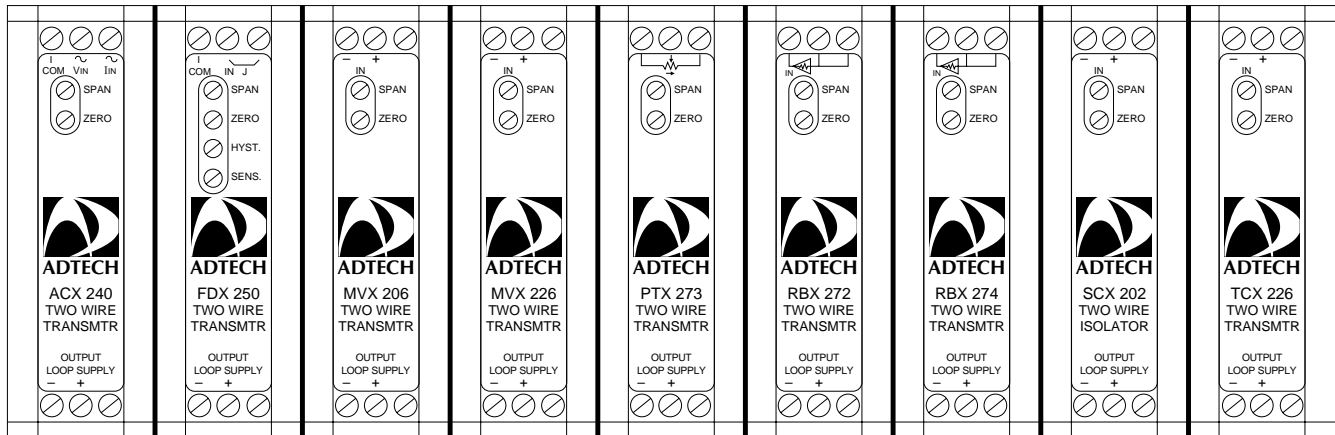

Typical Connection

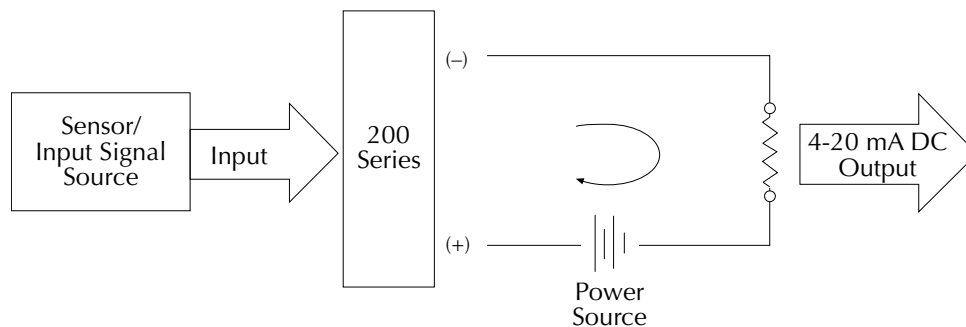

Outline & Mounting

DIN Mount (Standard)

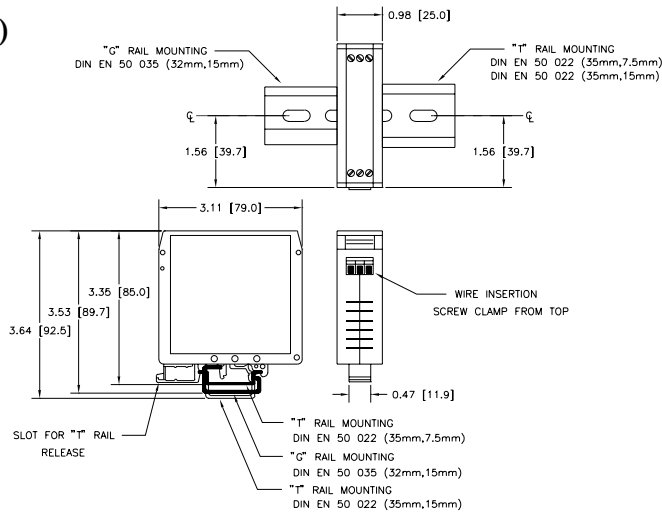

Snap Track Option H 25

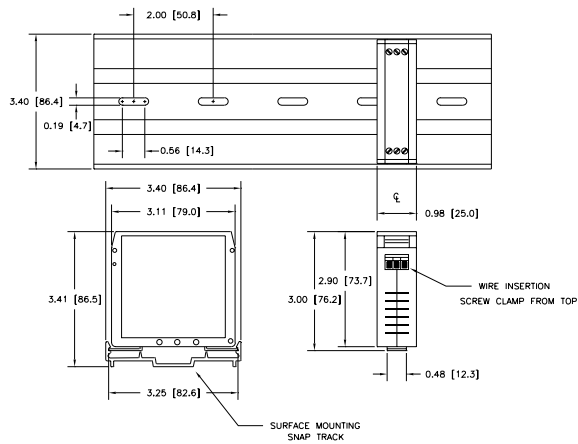

Surface Option H 26

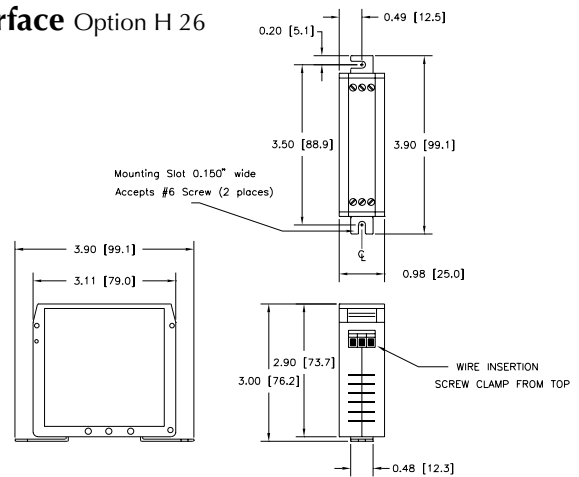

NEMA 4 Option H 27

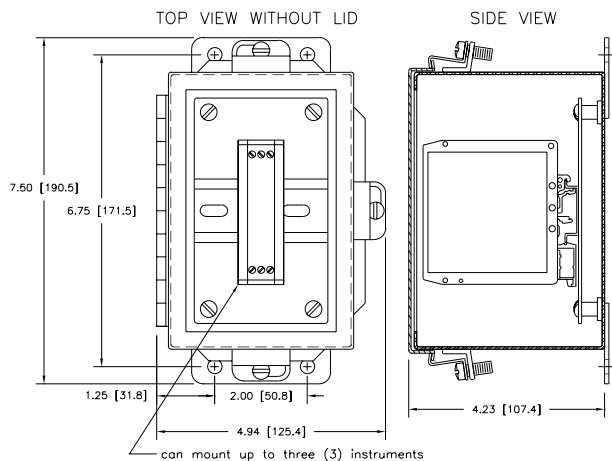

NEMA 7 Option H15D

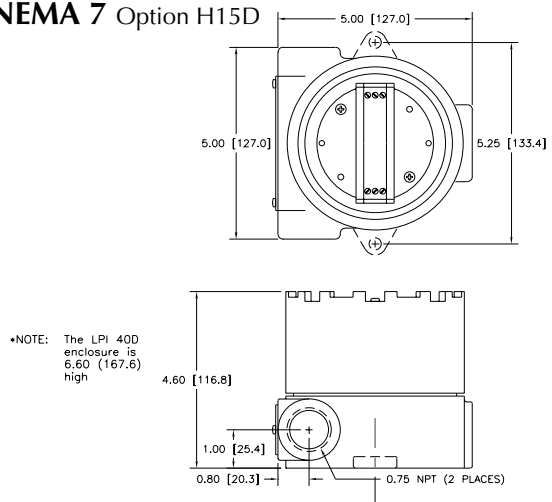

Represented by:

