



Description

Even the “smartest” transmitter is only as good as its ability to stay up and on the job. You paid extra for HART® capabilities. Now you can use the HFA HART Fault Alarm to make sure you’re getting a full return on that investment.

Avoid Costly False Shutdowns

Our HFA is like having a field technician watch the performance of your HART instrument 24-hours-a-day. Installed “transparently” on to a point-to-point temperature, pressure, level, or flow HART (4-20mA) transmitter loop, the HFA continually “reads” the HART digital diagnostic messages that continuously ride on the 4-20mA loop. If the process sensor input, the analog output, or the HART transmitter is not behaving properly, the HFA sends an instrument fault (contact closure) alarm to let you know. It will help you identify a potential problem before a shut-down happens. See the back page for details on configurable alarm trip options.



The HFA HART Fault Alarm is like having a field technician watch your important smart HART instrument loops 24-hours-a-day.

Features

- **Fully configurable alarm capability.** With the flick of a switch, you can constantly monitor any combination of up to six HART instrument health status indicators (see the back page for details).
- **Easy to use; No loop burden.** A 4-wire device, you can add the HFA anywhere on a point-to-point HART loop as either a Primary or Secondary HART Master.
- **Industry-first digital processing.** The HFA monitors the transmitter’s digital status data rather than its analog output. Because of this, it is relatively immune to the effects of ambient interference, ground loops, or transmitter saturation.

Figure 1. The HFA monitors a HART instrument’s “health”.

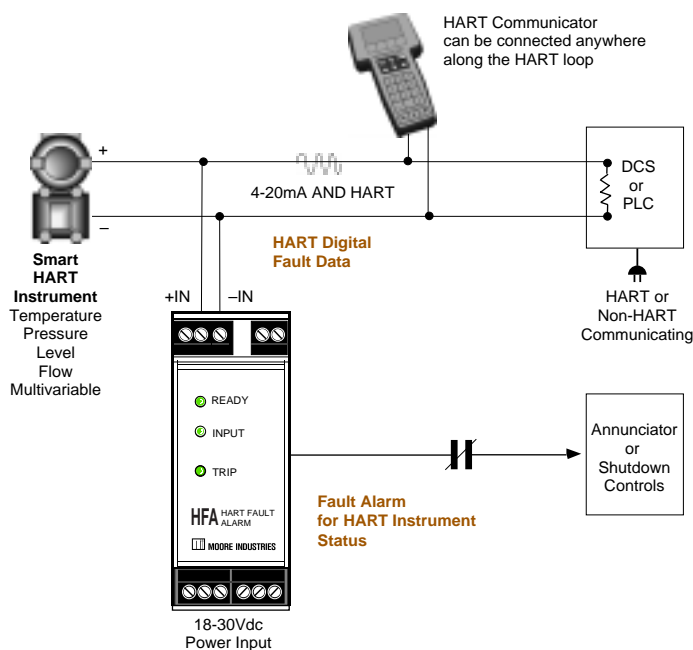

Certifications

CE: Conformant – EMC Directive 89/336/EEC EN 50081-2, 1993, EN 61010-1, 1993 and EN 50082-2, 1995

* HART is a registered trademark of the HART Communication Foundation.

HFA

HART Fault Alarm

Specifications

<p>Performance</p> <p>Alarm Response Time (Defined as the time from field instrument's reporting a fault until HFA trips): $H^* + 150$ milliseconds (msec), max. + period for # of Retries and Delay setting</p> <p>Alarm Trip Delay (Configured w/number of Retries setting): 0, 3, 6, or 9 seconds</p> <p>Isolation: 1000Vrms between case, input, and output</p> <p>Power Consumption: 0.8 to 1.4W, nominal; 2.5W with TX option installed</p> <p>Input Over-Range Protection: $\pm 5Vdc$</p>	<p>Ambient Conditions Ratings</p> <p>Operating Temperature Range: -25 to $85^{\circ}C$ (-13 to $185^{\circ}F$)</p> <p>Storage Temperature Range: -40 to $85^{\circ}C$ (-40 to $185^{\circ}F$)</p> <p>Relative Humidity: 0 to 95%, non-condensing</p> <p>RFI/EMI Protection: 30V/M - ABC \leq with no effect on operation</p> <p>Adjustments Easy-access, internal DIP switch sets: HART Primary/Secondary Master status; Alarm Trip Options; Latching/Non-Latching relay function;</p>	<p>Adjustments # of Retries and Alarm Trip Delay (0, 3, 6, or 9 seconds); # of Retries + Delay or # of Retries only</p> <p>Indicators LEDs: TRIP LED shows green for non-alarm condition, red for alarm; READY LED is on during normal operation, off in the event of a failure/alarm; INPUT LED shows green for input with valid HART communications, red for comms failure</p> <p>Weight 337 g (11.9 oz)</p>
--	---	---

*H = HART Foundation specifies 500msec response time in Normal Mode, 333msec in Burst Mode

Ordering Information

Unit	Input	Output	Power	Option	Housing
HFA HART Fault Alarm	HART 4-20mA into 250 Ω with digital data superimposed (HART version 4.5 or later); accepts HART input directly from a HART temperature, pressure, level, flow, or multivariable transmitter	1PRG Single-Pole/Double-throw HART Fault alarm Configurable for: Failsafe or Non-Failsafe, Latching or Non-Latching operation (Relay rated 1 Form C, 5A @ 250Vac, 50/60Hz, non-inductive)	18-30DC 18-30Vdc, $\pm 10\%$	-TX Transmitter Excitation enables HFA to provide power to the HART transmitter; 24Vdc, $\pm 5\%$, 23mA	DIN Universal DIN-style housing mounts on 32mm G-type rail (EN50035), and 35mm Top Hat DIN rail (EN50022)

When ordering, specify: Unit / Input / Output / Power / Option [Housing]
Model number example: HFA / HART / 1PRG / 18-30DC / -TX [DIN]

Versatile Alarm Trip Options

Using the **Field Device Status Byte** data that is inherently part of the HART protocol, the HFA configures to provide an alarm output if it detects one, some, or all of the following conditions:

Field Device Malfunction (BIT#7)—The HART transmitter is experiencing a hardware error or failure.

More Status Available (BIT #4)—There is more HART fault information available than can be sent as part of the normal HART query process.

Primary Variable Analog Output Fixed (BIT#3)—The HART transmitter is no longer responding to process changes. Its output is being held at the default value.

Primary Variable Analog Output Saturated (BIT #2)—The HART transmitter's output is beyond the upper or lower limits that it was programmed to measure. It is no longer reflecting input changes.

Non-Primary Variable Out of Limits (BIT #1)—A non-primary sensor input signal is beyond the upper or lower limits that the transmitter was set to measure.

Primary Variable Out of Limits (BIT #0)—The sensor input is beyond the upper or lower range limits that the HART transmitter was programmed to measure.

Figure 2. HFA Dimensions

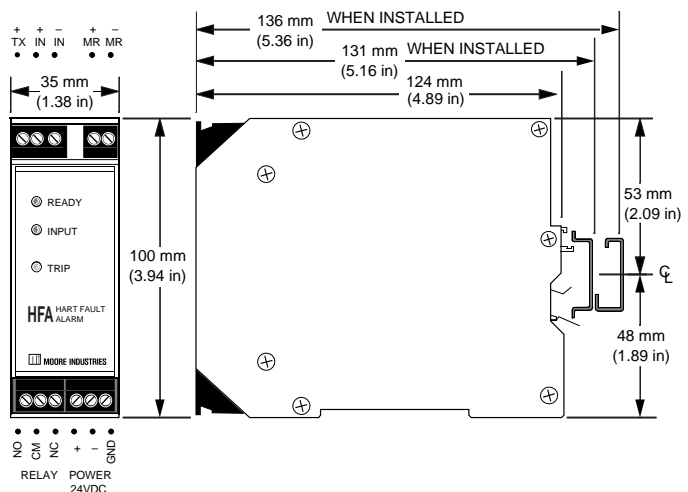

The Interface Solution Experts

United States
 Tel: (818) 894-7111
 FAX: (818) 891-2816

Australia
 Tel: (02) 9525-9177
 FAX: (02) 9525-7296

Belgium
 Tel: 03/448.10.18
 FAX: 03/440.17.97

Netherlands
 Tel: (0)344-617971
 FAX: (0)344-615920

United Kingdom
 Tel: 01293 514488
 FAX: 01293 536852