



## Description

The industry-first SPA Site-Programmable HART Loop Monitor and Alarm helps you keep track of a smart HART instrument's performance 24-hours a day.

### The SPA is ideal for continuously monitoring:

- Smart Temperature, Pressure, Level, and Flow Transmitters
- Smart Multivariable Transmitters
- Smart Valves and Positioners

### Monitors Process Conditions & Instrument Health

The SPA installs “transparently” across the 4-20mA loop of a smart valve or transmitter. Reading the HART digital information that “rides” on these wires, the SPA provides process information and fault diagnostic “health” warnings that were previously available only by connecting a HART communicator to the loop or using a HART-based DCS.

**Relay and Analog Outputs** The SPA provides up to four independent relay outputs that can be used to provide alarms when process conditions fall outside of user-selectable high and/or low limits, or if the HART instrument “health” is in question. The contact closure alarms can be used to warn of unwanted conditions, or provide emergency shutdown. An optional analog output can send the primary variable to an alternate readout device, break out an additional variable (second, third or fourth) from a multivariable transmitter, or track the stem position of a smart valve.

**Figure 1.** Delivering versatile input/output choices, the SPA with HART can be protected against harsh environments with one of our R-BOX enclosures.

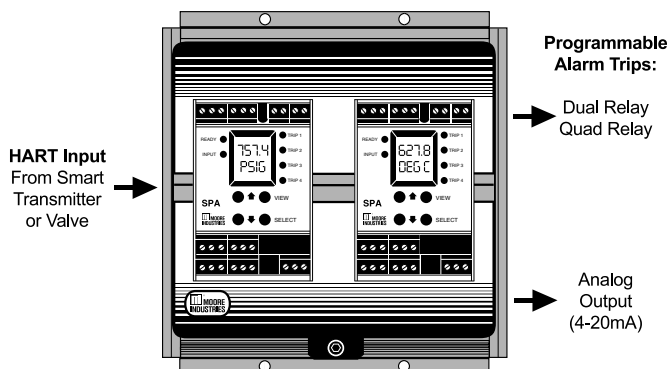

*The SPA Site-Programmable HART Alarm features a metal, RFI resistant housing that snaps onto standard rails.*

## Features

- **HART transmitter/valve watchdog.** “Invisibly” mounted on the loop, the SPA is like having a technician with a hand-held communicator monitoring a HART field device or valve 24-hours-a-day for abnormal conditions.
- **“Break out” an analog signal.** The SPA retransmits an isolated 4-20mA signal that represents any of the four dynamic variables from a HART device. This could be the primary, second, third, or fourth variable from a multivariable transmitter, density from a coriolis meter, or stem position for a valve.
- **Avoid false shutdowns.** By reading HART diagnostic information, the SPA can be configured to send an alarm if the smart transmitter or valve is not behaving properly. This can be used to help distinguish between non-critical instrument faults and actual critical process conditions.
- **On-site programming with display.** The SPA sets up with on-board controls. Process data and fault messages can be viewed on the SPA’s display.

### Certifications



Canadian Standards Association (CSA)  
General (Ordinary) Location – NRTL/C



CE Conformant – EMC Directive 89/336/EEC  
EN 50081-1, 1993 and EN 50082-1, 1995

All product names are trademarks of their respective companies.  
HART is a registered trademark of the HART Communication Foundation.

# SPA

## HART® Loop Monitor and Alarm

### Monitor HART Instrument Health

The HART protocol provides for remote access to diagnostic and performance analysis information. The key to capitalizing on this advantage is to continuously monitor and use both the digital health (Field Device Status) and dynamic variable information that is always riding on a HART 4-20mA loop.

**Smart valve monitoring.** A recent study indicates that more than half of all valves in the process industries fail to meet the desired level of performance. When a valve sticks, it begins a chain reaction of jumpy operation and process surges, eventually resulting in loop upset. The SPA tracks the smart valve's performance by listening in to the flow of digital information from the smart positioner.

Additionally, it can provide relay outputs offering insight into other conditions, such as valve position (open/closed), low actuator pressure, positioner temperature (high/low), or a change of any of seven HART status bits that warn of abnormal conditions.

**Specific Error Messages.** Using the Field Device Status Byte data that is part of the HART protocol, the SPA provides an alarm if the HART instrument, its process input, or output is not within prescribed limits. The SPA programs to initiate an alarm if any of the following fault conditions are detected:

- Primary Variable Out of Limits
- Non-Primary Variable Out of Limits
- Primary Variable Analog Output Out of Limits
- Primary Variable Analog Output Fixed
- Cold Start
- Field Device Malfunction
- More Status Available

### Monitors its Own Status

For additional loop security, the SPA incorporates advanced self-diagnostics. It continuously monitors its own status, and can be programmed to initiate an alarm if it senses an abnormal condition. The SPA's LCD provides a message that indicates the type of condition that has occurred.

**Figure 2.** The SPA connects in parallel on to a HART loop to monitor the information contained in a HART digital string.

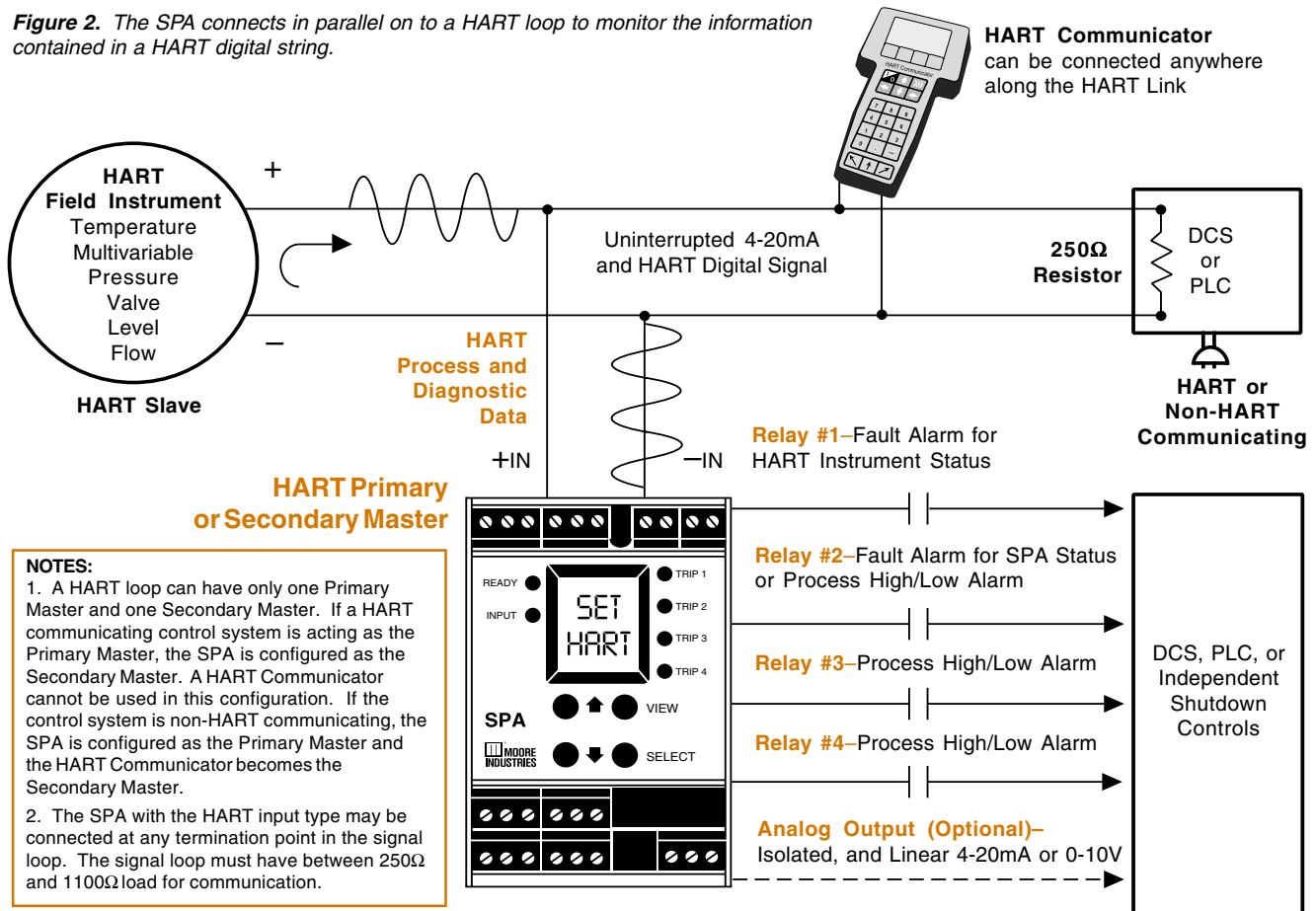

## Monitor Multivariable Signals

Multivariable transmitters accept Pressure, Differential Pressure and Temperature inputs and from this information calculate Mass Flow of the process fluid. Their advantage is that they replace both the need to connect three individual transmitters to the DCS and the programming in the DCS required to calculate mass flow. The disadvantage is that the only output signal available from the Multivariable transmitter is mass flow. If the user needs an independent signal for either Pressure or Temperature, another transmitter and its associated installation costs would typically be required.

**The HART advantage.** The HART protocol inherent in multivariable transmitters not only provides the ability for remote configuration, but it also provides access to the process and diagnostic status information. This information is always digitally riding on the 4-20 mA loop and the SPA HART provides a way to access this information.

**Monitor Second, Third, and Fourth Variables.** Of the four dynamic process variables, mass flow is the primary. The second is typically Pressure, the third is Temperature, and the fourth is volumetric flow. The SPA HART can be configured using its on-board push buttons to monitor these variables for alarming or local display purposes. The SPA also monitors the

status bits of the multivariable transmitter and will provide a relay contact should there be any malfunction within the transmitter.

Each of the SPA's alarm relays can be individually configured to alarm if it senses unwanted high and/or low process conditions from the Primary, Second, Third, or Fourth Variables. The SPA's signals can be sent to a DCS or to a backup monitoring system.

**“Break out” an analog signal.** In addition to alarm outputs, the SPA's Analog Output (–AO Option) can be configured to represent either the Pressure or the Temperature variable and also provide this measurement to the DCS without the requirement for a separate transmitter.

For safety critical applications, the Analog Output is configured to represent the Primary Variable of mass flow so that the same measurement can be reliably shared with both the DCS and the safety system.

**Alarms can be individually assigned.** The SPA HART Alarm's three process alarms can be assigned to monitor any combination of a multivariable transmitter's Primary, Second, Third, and Fourth HART variables. For example, all alarms can be assigned to monitor one process variable, or each of the alarms can be set to respond to different process variables. Any combination is possible.

**Figure 3.** The SPA's four independently configurable relays can be assigned to any variable

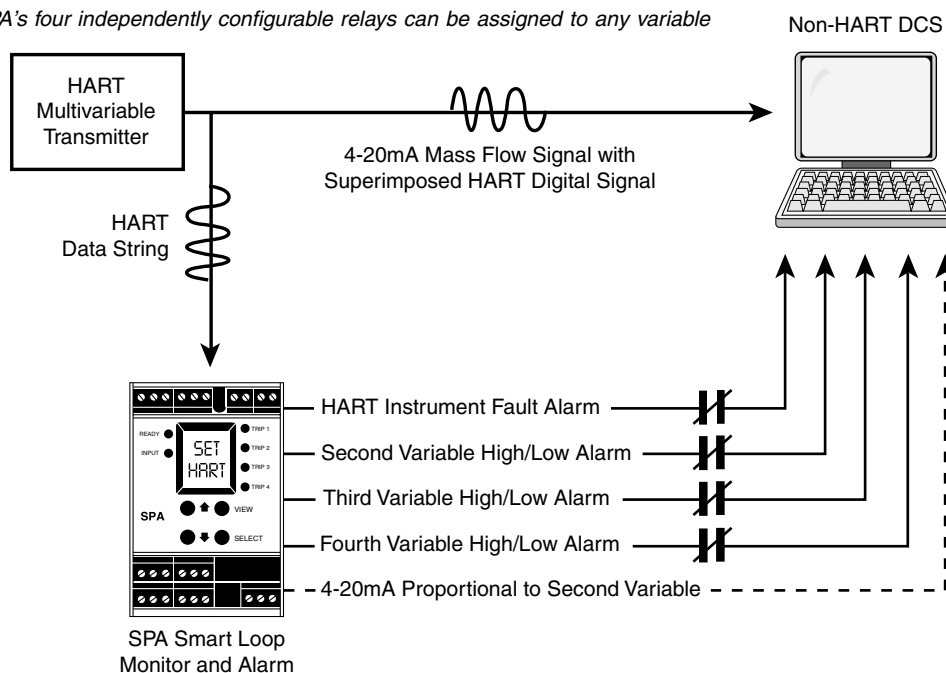

# SPA

## HART® Loop Monitor and Alarm

### Cost-Effective Emergency Shutdown Valve Testing

Estimates indicate that as much as 50 percent of loop operational problems can be blamed on final control elements. A valve may malfunction because of fluid contamination, corroded shafts, an inadequate air supply, a shorted or open solenoid coil, or in-line obstructions. This can be a particularly sticky situation for emergency shutdown valves.

The best way to perform an on-line test is to stroke the valve from 0-100% (full open/full close), but to close an emergency shutdown (ESD) valve normally necessitates a process shutdown. Operation managers are not able to initiate a total shutdown frequently enough to satisfy various safety standards.

**Partial stroke testing.** One alternative to testing ESD valves without a system shutdown is through partial valve stroking. This can be accomplished by applying a closure signal and either monitoring valve response visually (which requires the presence of a field technician), or using limit switches (which require installation, calibration, wiring, and maintenance).

**HART partial stroke testing.** Using the power of HART communication, valve testing can be accomplished without limit switches, a costly shutdown, or a field technician.

Install a smart HART positioner on the valve and change the DCS control signal from discrete on/off to 4-20mA. Install the SPA HART to access the HART digital data and extract stem position. Configure the SPA to provide a 4-20mA signal proportional-to-stem position and to trigger relay outputs at up to three designated percentages of travel.

For example, using the example in Figure 4 below, use a Logic Solver (DCS or PLC) to apply a 90% signal to the valve. When the valve reaches the 90% set point, the HART loop relay will trip, and the signal is returned to 100% value by the Logic Solver, reopening the valve. This determines that the valve will reach the 90% travel point without sticking, and because it is immediately reopened, you have minimized the time the process flow is impeded.

A second relay trip point could be set at 100% travel to insure that the valve reopens completely after the test, while a trip point at 0% would interlock to prove that the valve closed all the way when asked to perform a complete shutdown. All the while, the SPA HART continuously monitors the HART positioner's health and alerts the operators to problems by means of a fourth relay.

The use of HART communication for online ESD valve testing can dramatically improve the safety integrity level of the loop at minimal cost.

**Figure 4.** The SPA HART used in conjunction with HART valve positioners provides a reliable and cost-effective ESD system.

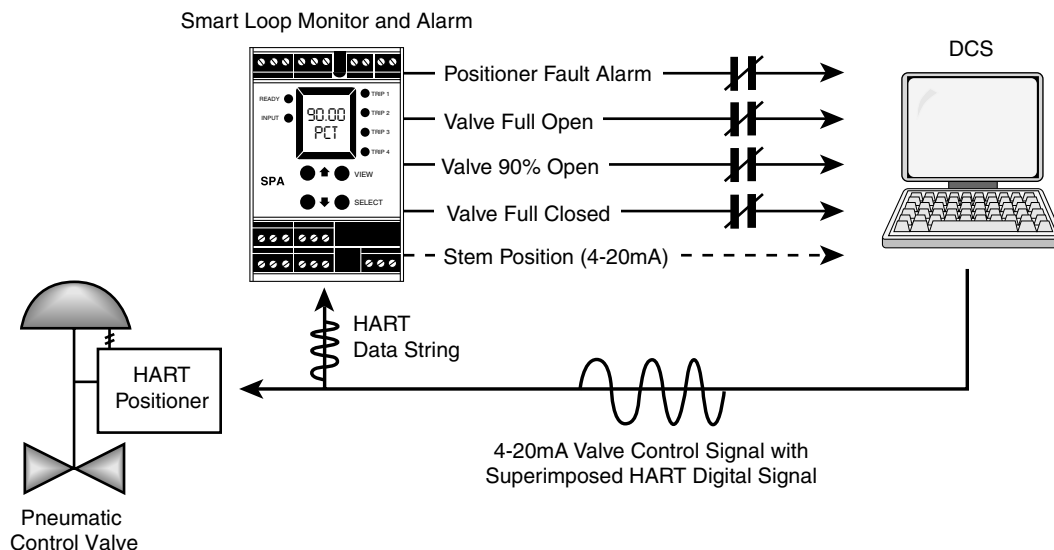

## On-Site Programming

Ranges, trip points, and other frequently changed operating parameters configure quickly and easily from the front panel keypad. Simple prompts on the SPA's LCD guide you through a "plain-English" selection menu. Available programmable functions include:

- Input type and range
- Zero and full scale
- Alarm trip points, high or low alarm, deadband, time delay, latching or non-latching
- Engineering unit readout (V, mA, %, °C, °F, psig, mV, ohms, custom, or blank)
- Position of LCD decimal point for custom engineering unit representation
- HART® operating parameters
- Upscale or downscale drive on sensor failure
- Standard and custom linearization curves
- Security password protection

## Quick Ranging Calibration

The SPA features our revolutionary Quick Ranging Calibration method. Using the push buttons (instead of potentiometers which can drift) and the integral display, precise zero and span settings can be made in seconds. All you have to do is scroll to the zero or span value you want. Once the correct value is displayed on the LCD, another push of a button locks the value into the SPA's memory.

## Auto Input Recognition

The SPA HART uses the digital information on a HART loop to automatically configure itself to match the primary variable's measurement type, range, and zero and span values. Or, disable this function and manually configure your SPA.

## Security Password Protection

A security password system can be used to protect setup data from unauthorized or inadvertent changes. Once the password protection feature is activated, the SPA's operating parameters cannot be altered unless the correct password has been entered on the keypad.

## Worldwide Power "Auto-Sensing"

Without adjustment, the SPA accepts any ac and dc power input (22-300Vdc and 90-260Vac)\*. Just apply power and you're up and running.

\* Units with CE approval must be ordered with fixed power supplies (24DC, 117AC, or 230AC). See the Ordering Information table for details.

## Analog Output Option

In addition to alarm outputs, the SPA provides an isolated, scaleable analog output that is proportional to one of the monitored process variables. It is essentially an alarm trip and process variable transmitter in one (see -AO option in the Ordering Information table).

## Real-time Process Readout

A front panel indicator provides menu prompts during configuration, then displays the selected real-time process variable in user-selectable engineering units.

## Custom 22-Point Linearization Curves

The SPA with HART can be programmed from the front panel keypad with up to 22 custom linearization points. The ability to plot a custom linearization curve is beneficial when non-linear input signals must be converted to linear output representations. Typical applications include monitoring a non-linear transducer, odd-shaped tank levels, and flow meter linearization.

**Figure 5.** Up to 22 custom linearization points can be selected and saved in the SPA's memory to compensate for non-linear input signals.

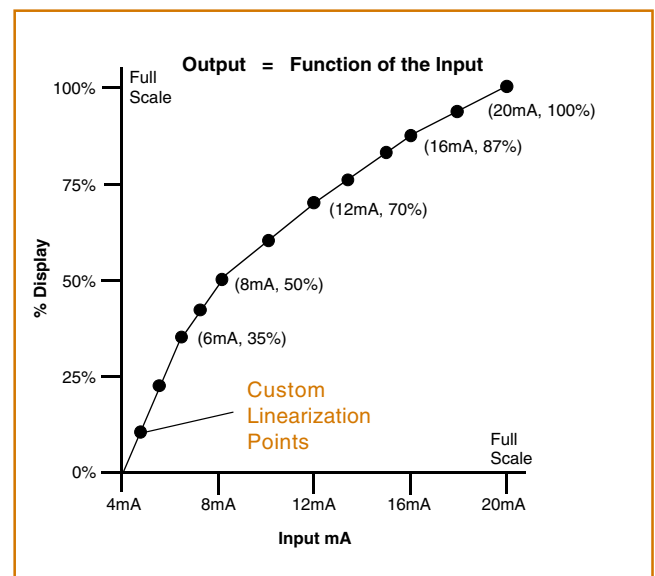

# SPA

HART® Loop  
Monitor and Alarm

## Specifications

<p><b>Performance</b></p> <p><b>Input Accuracy:</b> Limited by the accuracy of the HART field instrument</p> <p><b>Display Accuracy:</b> ±1 digit</p> <p><b>Deadband:</b> Full display range available; equal to maximum input range in user-set engineering units</p> <p><b>Digital Response Time:</b> Defined by HART protocol as 500 milliseconds (msec), normal mode, 333 msec in burst mode</p> <p><b>Alarm Response Time:</b> Digital response time + 150 msec, max. (Defined as time from the field instrument's reporting a fault until the SPA alarm is tripped)</p> <p><b>Alarm Trip Delay:</b> Programmable from 0-120 seconds</p> <p><b>Line Voltage Effect:</b> ±0.005% of output span for a 1% change in line voltage (ac or dc)</p> <p><b>Isolation:</b> 1000Vrms between case, input, output (units with -AO option) and power terminals</p> <p><b>Power Consumption:</b> 2-4W, nominal; 6W, maximum</p> <p><b>Input Over-Range Protection:</b> ±5Vdc</p>	<p><b>Analog Output (-AO Option) Performance</b></p> <p><b>WITH ANALOG OUTPUT Output Accuracy:</b> ±0.03% of output span (includes the combined effects of linearity, hysteresis, repeatability, and adjustment resolution)</p> <p><b>Output Stability:</b> ±0.1% of calibrated span, maximum, over 6 months</p> <p><b>Output Response Time:</b> 500 milliseconds, max.</p> <p><b>Ripple (up to 120Hz):</b> Current output, 10mV peak-to-peak max. when measured across a 250Ω resistor; Voltage output, 50mV peak-to-peak max.</p> <p><b>Output Limiting:</b> 117% of span max., 115% of span typical</p> <p><b>Load Effect:</b> ±0.01% of span from 0 to maximum load resistance on current output</p> <p><b>Ambient Conditions</b></p> <p><b>Operating Range:</b> -25°C to +65°C (-13°F to +149°F)</p> <p><b>Storage Range:</b> -40°C to +80°C (-40°F to +176°F)</p> <p><b>Ambient Temperature Effect:</b> ±0.005% of output span per °C max.</p> <p><b>Relative Humidity:</b> 0-95% non-condensing</p> <p><b>RFI/EMI Protection:</b> 30V/m - ABC ≤0.5% error in reading when tested according to SAMA standard PMC 33.1; 20V/m when tested according to IEC1000-4-3-1995</p>	<p><b>Adjustments</b> Front panel push buttons control settings for zero, span, alarm trip points, HART parameters etc.; Easy access internal settings select current (source or sink) or voltage output, failsafe/non-failsafe, and high/low alarm functions; Internal jumper and menu password protect parameter settings</p> <p><b>Indicators</b></p> <p><b>LCD:</b> 2x4 character, backlit, alphanumeric readout accurate to the nearest digit.</p> <p><b>Range:</b> -9999 to 9999; Auto decimal positioning, or programmable to one or two places</p> <p><b>LEDs:</b> Dual-color TRIP light (one for each relay) shows green for non-alarm, red for alarm; READY light indicates normal operation, extinguishes in the event of any internal failure; Dual-color INPUT light shows green for input with valid HART communications, red for communications failure; Dual-color TRIP1 light shows green for HART in non-alarm, red for HART failure.</p> <p><b>Weight</b> 456 to 513 g (16.1 to 18.1 oz)</p>
---	--	---

### Factory Configuration Available

We can deliver your SPA HART Loop Monitor and Alarm pre-configured to your specifications, and ready to install. Consult your Moore Industries Sales Representative or call one of our Interface Solution Centers (see the back of this data sheet for details).

## Ordering Information

Unit	Input	Output	Power	Options	Housing
<b>SPA</b> Site-Programmable Alarm	<b>HART</b> Accepts a HART digital protocol input directly from a HART temperature, pressure, level, flow, valve positioner, or multivariable transmitter (HART version 5.4 and earlier)	<b>2PRG</b> Dual Relays RELAY #1 is a HART instrument fault alarm RELAY #2 configures as either a SPA instrument fault alarm or as a process variable alarm  <b>4PRG</b> Quad Relays RELAY #1 is a HART instrument fault alarm RELAY #2 configures as either a SPA instrument fault alarm or as a process variable alarm RELAY #3 is a process variable alarm RELAY #4 is a process variable alarm  Process variable alarm relays configure independently for: High or Low Trip Normally Open or Normally Closed Failsafe or Non-Failsafe Latching or Non-Latching Trip Delay  (Relays are single-pole/double-throw (SPDT), 1 form C, rated 5A @ 250Vac or 24Vdc, 50/60Hz, non-inductive)	<b>U</b> Universal, 4-wire (line) power; accepts any power input range between 22-300Vdc or 90-260Vac  For CE approved units, specify one of the following: <b>24DC</b> ±10% <b>117AC</b> ±10% <b>230AC</b> ±10%	<b>-AO</b> Analog output scaleable for any range between 0-20mA (4mA span, min.) into 1200Ω or 0-10V (1V span, min.) into 10KΩ <b>-DPDT</b> Double-pole/double-throw relays, 2 form C relays, rated 5A @ 250Vac, 50/60Hz, non-inductive (2PRG output types only) <b>-HS</b> Hermetically sealed relays, rated 0.5A @ 117Vac and 2A @ 28Vdc (2PRG output type only)	<b>DIN</b> Universal DIN-style housing mounts on 32mm (EN50035) G-type and 35mm (EN50022) Top Hat DIN-rails

**When ordering, specify:** Unit / Input / Output / Power / Options [Housing]  
**Model number example:** SPA / HART / 4PRG / U / -AO [DIN]

### Programs as a Primary or Secondary Master in a Point-to-Point HART Network

The SPA programs from the front panel keypad to act as a HART loop's Primary Master or Secondary Master in a HART master/slave system. Available programmable HART parameters include:

#### Hart Operating Mode

**Normal Mode**—The SPA operates in a Poll/Response communication mode. It queries (polls) the HART transmitter 2 times per second requesting the current process variable status and HART instrument's "health" status. The HART instrument responds with the requested data.

**Burst Mode**—In this mode, the HART instrument is programmed to continuously transmit its process variable and "health" status. The SPA samples the continuous HART data 3 times per second.

#### Number of Tries to Initiate Communication

When powered up, the SPA looks for the HART transmitter (slave device) connected on the point-to-point network. It can be programmed to initiate a search from 1 to 5 times. If the HART instrument is not found during the search(s), the SPA displays the fault message "NO HART" on its front panel LCD.

#### Number of Preambles Required

When configured to operate in Normal Mode, the SPA programs from the keypad to send between 1 and 12 (inclusive) preambles to initiate a query with a HART instrument (the number required for each HART instrument is specified by the manufacturer).

#### Connecting the SPA HART in Series

There are some applications where it may be desirable to pass the 4-20 mA loop current through the SPA instead of connecting it digitally in parallel with the loop. This option requires a factory installed internal resistor.

# SPA

## HART® Loop Monitor and Alarm

Figure 6. SPA HART Dimensions.

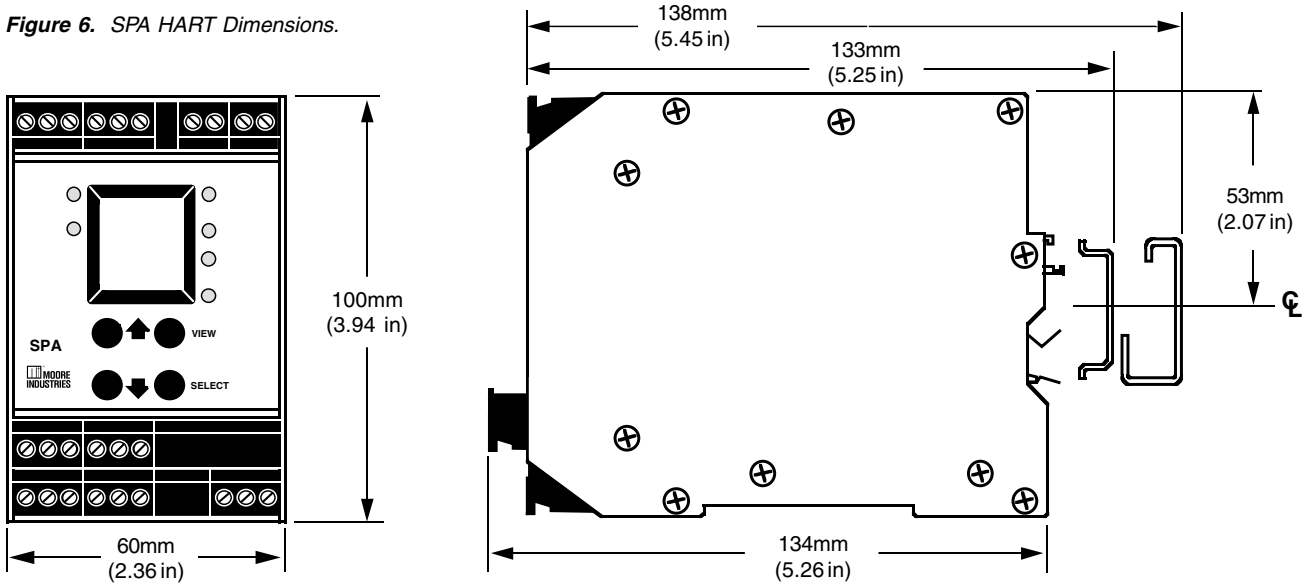

Table 1. Terminal Designations.

INPUT	T1	T2	T3	T4	T5	T6	T7	T8	T9	T10	T11
<b>HART Input</b>	TX	+IN	-IN	no label			not present	MR	MR	+AO	-AO
OUTPUT	M1	M2	M3	M4	M5	M6	M7	M8	M9	M10	M11
<b>Dual Alarm (2PRG) w/DPDT</b>	NO2	CM2 relay 1	NC2	NO2	CM2 relay 2	NC2	Not Present				
<b>Quad Alarm (4PRG)</b>	NO3	CM3 relay 3	NC3	NO4	CM4 relay 4	NC4	Not Present				
OUTPUT / POWER	B1	B2	B3	B4	B5	B6	B7	B8	B9	B10	B11
<b>All HART</b>	NO1	CM1 relay 1	NC1	NO1	CM1 relay 2	NC1	Not Present	Not Present	Power AC DC	Power AC DC	GND

**NOTES:**

1. Terminal blocks can accommodate 14-22 AWG solid wiring.
2. HART input is not polarity sensitive.
3. MR and ±AO labeling is present only when the unit is equipped with those options.

**KEY:**

MR = Manual Reset  
 INA/B = Current input from HART transmitter  
 NC/NC# = Normally Closed  
 CM/CM# = Common

AO = Analog Output  
 NO/NO# = Normally Open  
 DPDT = Double-pole/Double-throw  
 GND = Ground

Terminal Position and Sensor Hook-Up Guides

