

September 2010

## Description

The TRUNKGUARD® TPS400 Fieldbus Power Supply provides isolated, conditioned power to up to four FOUNDATION fieldbus™ H1 segments. Designed for flexibility and easy implementation, the TPS400 is fully compliant with FF831-1 (the technical specification for fieldbus power supplies), and is FOUNDATION fieldbus registered.

### Complete Device Coupler Compatibility for General and Hazardous Area Installations

For use with the TRUNKGUARD TPS400 Fieldbus Power Supply, MooreHawke offers Fieldbus Device Couplers for installation in General Purpose, Zone 2/Division 2 locations (TRUNKGUARD Model TG200), Zone 1 locations (TRUNKGUARD Model TG300) and for I.S. Entity and FISCO applications (Model SPURBARRIER™ SB Series). The TPS400 also works perfectly with compatible third-party device couplers.

**Figure 1.** The TRUNKGUARD TPS400 Fieldbus Power Supply and Conditioner provides properly conditioned power to a FOUNDATION fieldbus H1 segment.

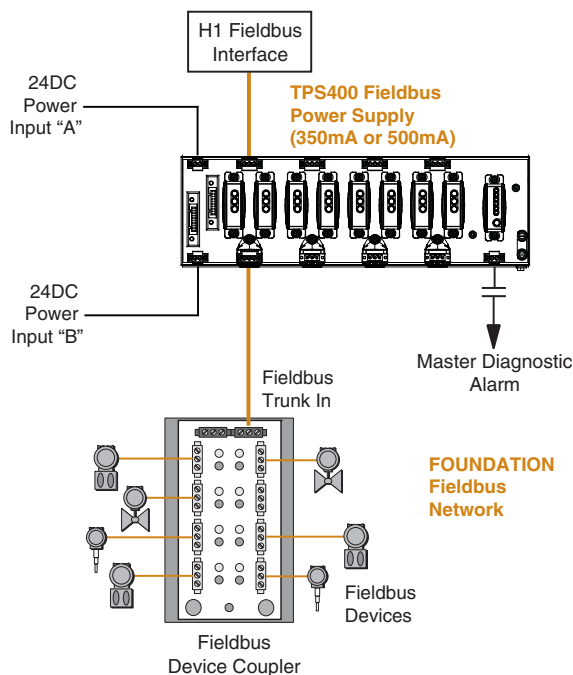

\* The TPS400 is appropriate for non-incendive applications when it is installed in a safe area and connected to a device coupler approved for non-incendive applications (such as the MooreHawke TRUNKGUARD TG200 Device Coupler).

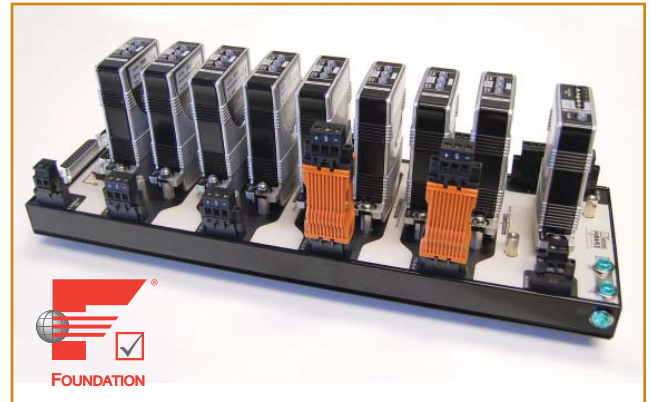

Featuring a rugged industrial metal housing, the TRUNKGUARD Fieldbus Power Supply provides fieldbus-conditioned power to up to four fieldbus segments.

## Features

- **Delivers up to 500mA per segment.** Available models supply 350mA (for non-incendive, energy-limited applications) or 500mA (for high current demand applications) of isolated, conditioned simplex (non-redundant) or duplex (redundant) power to up to four segments.
- **High-availability, modular design.** Provides individual power conditioner modules for each segment. Modules are hot-swappable with load-sharing in redundant pairs to maintain power to the segment in the instance that one module in a pair needs to be removed.
- **Multi-segment H1 connectors.** Plug-to-plug connectors that support four-segment wiring (when supported by the H1 host System) deliver simple, error-free wiring to a DCS and reduced installation time.
- **Economical fieldbus physical layer diagnostics.** An optional Diagnostics Module (FDM252) provides a master alarm and LED-based alarms for segment noise, DC voltage levels and conditioner status faults.
- **Pluggable surge protection (optional).** Surge protection with a three-element surge arrester is available per segment to protect the TPS400 and the DCS from surges coming in on the trunk cables.

### Certifications



FOUNDATION Fieldbus Registered



CE Conformant - EMC Directive 2004/108/EC EN61326

# TPS400

## TRUNKGUARD® Fieldbus Power Supply (General Purpose and Non-Incendive Applications\*)

### Modular Design Allows for Simplex and Duplex Configurations and “Hot Swapping” Under Load

The TPS400 consists of a DIN Carrier populated with individual Power Conditioner Modules (TPS202 or TPS205) for each segment. The DIN Carrier can be either a simplex (TPS401) or a duplex (TPS402) type. Both simplex and duplex DIN Carriers support four segments, and have pluggable connectors for redundant DC power supply inputs.

To accommodate multi-segment connection to popular Distributed Control Systems, pluggable connectors on the TPS400 DIN Carrier connect the H1 host system input and field output trunk wiring.

Power Conditioner Modules are available in two models: the TPS202 rated at 350mA and the TPS205 rated at 500mA. Each provides isolated, conditioned power, and is hot-swappable under load. When mounted in a duplex (redundant) configuration, the Power Conditioner Modules load share, and either conditioner module may be removed without disturbing the segment. Each Power Conditioner

Module comes with dual color alarm LEDs that for the TPS400 indicate short circuits, high field current and low module output voltage.

### Optional Surge Suppression per Segment—

Three element surge suppression for each segment is also available (SPM201) to protect the TPS400 and the DCS from surges coming in on the trunk cables. The very simple to install SPM201 plugs into the DIN Carrier, and can be ordered with the TPS400 or added at any time in the future.

### Optional Physical Layer Fieldbus Diagnostics

**Module—**Each DIN Carrier provides for mounting of a MooreHawke Fieldbus Diagnostics Module (FDM252). When the FDM252 is installed on the DIN Carrier, the TPS400 provides realistic and practical physical layer diagnostic information. The diagnostic module is fully isolated from each segment, and provides LED based alarms and a master failsafe alarm contact output (open on alarm). See Page 3 for additional information.

**Figure 2.** The TRUNKGUARD Fieldbus Power Supply provides simplex (non-redundant) or duplex (redundant) power to each fieldbus segment.

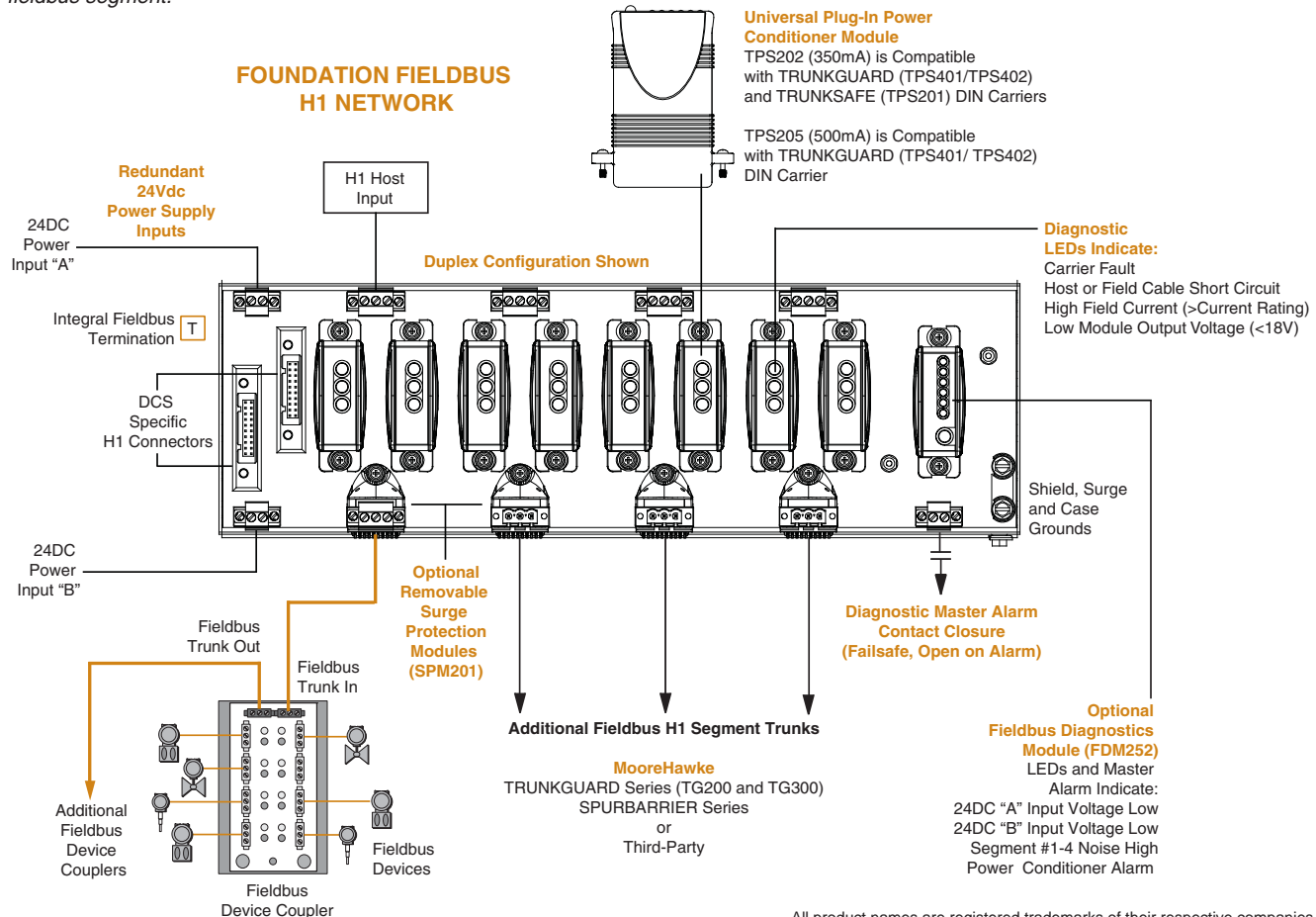

# TPS400

TRUNKGUARD® Fieldbus Power Supply  
(General Purpose and Non-Incendive Applications\*)

## Specifications

<p><b>Performance</b> <b>TPS DIN Carrier</b>  <b>Number of Segments:</b> 4  <b>Supply Voltage:</b> 19.2 to 32Vdc, reverse polarity protected  <b>Power Requirements:</b> 13.5VA per segment for 350mA model; 22.5VA per segment for 500mA model  <b>Terminator:</b> 100 ohms/1microFarad per segment</p>	<p><b>Performance</b> <b>TPS205 Power Conditioner Module</b>  <b>Output Capacity:</b> 500mA per segment; up to 28V (no load)  <b>DC/DC Isolation:</b> 500Vdc (segment to power supply)  <b>Power Dissipation:</b> 8W max. per segment at full load (shared in duplex mode)</p>	<p><b>Master Alarm Output</b> <b>Type:</b> Relay (failsafe, normally open)  <b>Contact Rating:</b> 5A@250Vac 50/60Hz or 24Vdc, non-inductive load</p>
<p><b>Terminals</b> <b>Type:</b> Pluggable with screw-clamp retaining screws  <b>Wire Size:</b> Handles 0.8-2.5mm<sup>2</sup>/12-24AWG cable sizes</p>	<p><b>Indicators</b> <b>LED (Power):</b> GREEN, normal; ORANGE, Output Voltage &lt;18V  <b>LED (Short):</b> GREEN, normal; RED, Cable Short  <b>LED (Open):</b> GREEN, normal; RED, Carrier Fault (no load)</p>	<p><b>Performance</b> <b>SPM201 Surge Protection Module</b>  <b>Complies with:</b>          -IEC 61158-2          -IEC 61643-21</p>
<p><b>Performance</b> <b>TPS202 Power Conditioner Module</b>  <b>Output Capacity:</b> 350mA per segment; up to 25.5V (no load)  <b>DC/DC Isolation:</b> 500Vdc (segment to power supply)  <b>Power Dissipation:</b> 5.5W max. per segment at full load (shared in duplex mode)</p>	<p><b>Performance</b> <b>FDM252 Fieldbus Diagnostics Module</b>  <b>Power Dissipation:</b> 0.5W maximum</p>	<p><b>Performance</b> <b>Max. Surge Current (8/20 microsecond):</b> 20KA  <b>Nominal Voltage Vn:</b> 32V  <b>Max. Continuous Operating Volt:</b> 35V  <b>Peak Common Mode:</b> 230V  <b>Nominal Rated Current In:</b> 650mA  <b>Nominal Discharge Current Isn (8/20 microsecond):</b> 3KA  <b>Limiting Voltage Vlim (8/20 microsecond):</b> 50V@3KA  <b>Line Attenuation Rs:</b> 1 Ohm</p>
<p><b>Indicators</b> <b>LED (Power):</b> GREEN, normal; ORANGE, Output Voltage &lt;18V  <b>LED (Short):</b> GREEN, normal; RED, Cable Short  <b>LED (Open):</b> GREEN, normal; RED, Carrier Fault (no load)</p>	<p><b>Indicators</b> <b>LED Type:</b> GREEN, Normal; RED, Fault  <b>LED A:</b> DC "A" Input Voltage Low (&lt;18V)  <b>LED B:</b> DC "B" Input Voltage Low (&lt;18V)  <b>LED 1:</b> Segment #1 Noise High (&gt;75mV p/p)  <b>LED 2:</b> Segment #2 Noise High (&gt;75mV p/p)  <b>LED 3:</b> Segment #3 Noise High (&gt;75mV p/p)  <b>LED 4:</b> Segment #4 Noise High (&gt;75mV p/p)</p>	<p><b>Ambient Conditions (All TPS400 Components and Options)</b> <b>Operating Range:</b> -20°C to +60°C (-4°F to +140°F)  <b>Storage Range:</b> -40°C to +85°C (-40°F to +185°F)  <b>Relative Humidity:</b> 0-95%, non-condensing  <b>RFI/EMI Immunity:</b> 10V/m@80-1000MHz, 1kHz AM when tested according to IEC61326</p>

### Physical Layer Diagnostics

The TPS400 provides for three levels of physical layer diagnostics:

**Integral Diagnostics**—Each Power Conditioner Module alerts of potential problems via on-board LEDs:

- Carrier Fault
- Host or Field Cable Short Circuit
- High Field Current (>Current Rating)
- Low Module Output Voltage (<18V)

**Optional Diagnostics Module**—The FDM252 Diagnostics Module adds a volt-free contact closure (open on alarm) for use as a Master Alarm (see NOTE), plus LEDs to indicate:

- DC "A" Input Voltage Low (<18V)
- DC "B" Input Voltage Low (<18V)
- Segment #1 Noise High (>75mV p/p)
- Segment #2 Noise High (>75mV p/p)
- Segment #3 Noise High (>75mV p/p)
- Segment #4 Noise High (>75mV p/p)

NOTE: The Master Alarm LED and relay indicate any alarm on the diagnostics module or on any of the segment power conditioners.

**Advanced Diagnostics**—The TPS400 is designed to support the connection of external third-party Advanced Diagnostics Modules. These modules are capable of monitoring multiple segments and then integrating the information into the host system's Asset Management Package.

The diagnostics data available allows easy analysis of signal and segment parameters such as bulk power or short circuit, as well as measurement of specific system and node physical layer values (e.g., segment noise or jitter levels, and cable unbalance detection).

Some systems also support extended functionality such as sophisticated alarming, trending, and report generation, plus an oscilloscope function which graphically represents fieldbus communications within a segment for easier analysis.

# TPS400

TRUNKGUARD® Fieldbus Power Supply  
(General Purpose and Non-Incendive Applications\*)

## Ordering Information

Description	Model Number
<b>1. Select a DIN Carrier and Order as a Separate Line Item:</b>	
DIN Carrier, 4-Segment Non-Redundant (Simplex) Power with One DB25 Multi-Segment Cable Connector**	TPS401-4-D
DIN Carrier, 4-Segment Non-Redundant (Simplex) Power with One Yokogawa Multi-Segment Cable Connector**	TPS401-4-Y
DIN Carrier, 4-Segment Redundant (Duplex) Power with Two DB25 Multi-Segment Cable Connectors***	TPS402-4-D
DIN Carrier, 4-Segment Redundant (Duplex) Power with Two Yokogawa Multi-Segment Cable Connectors***	TPS402-4-Y
<b>2. Select the Type and Number of Power Conditioner Modules Required and Order as Separate Line Item:</b>	
350mA Fieldbus Segment Power Conditioner Module	TPS202
500mA Fieldbus Segment Power Conditioner Module	TPS205
<b>3. Select Optional Features (Not Required):</b>	
Fieldbus Diagnostics Module	FDM252
Surge Protection Module (specify one per active segment requiring protection)	SPM201
DB25/DB25 Cable (2m) for connection to the TPS401-4-D/TPS402-4-D DIN Carrier (other lengths available, consult factory)	804-009-26

\*\*Non-Redundant (Simplex) Configuration—Requires one position on the DIN Carrier and one Power Conditioner Module (TPS202/TPS205) to power each fieldbus segment. The DIN Carrier must be ordered as Non-Redundant (Simplex), and can not be used in a Redundant configuration later. Any number of Power Conditioner Modules can be ordered on a DIN Carrier, and additional Power Conditioner Modules can be added in unoccupied DIN carrier positions at any time.

\*\*\*Redundant (Duplex) Configurations—Require two positions on the DIN Carrier and two Power Conditioner Modules (TPS202/TPS205) to power each fieldbus segment. The DIN Carrier must be ordered as Redundant (Duplex). If one of the pair fails or is removed, an alarm will activate. A shorting bar or wire link may be used to disable the alarm allowing for continued simplex operation. Any number of Power Conditioner Modules can be ordered and installed in pairs on a DIN Carrier, and additional Power Conditioner Modules can be added in pairs in unoccupied DIN Carrier positions at any time.

Figure 3. Installation Dimensions.

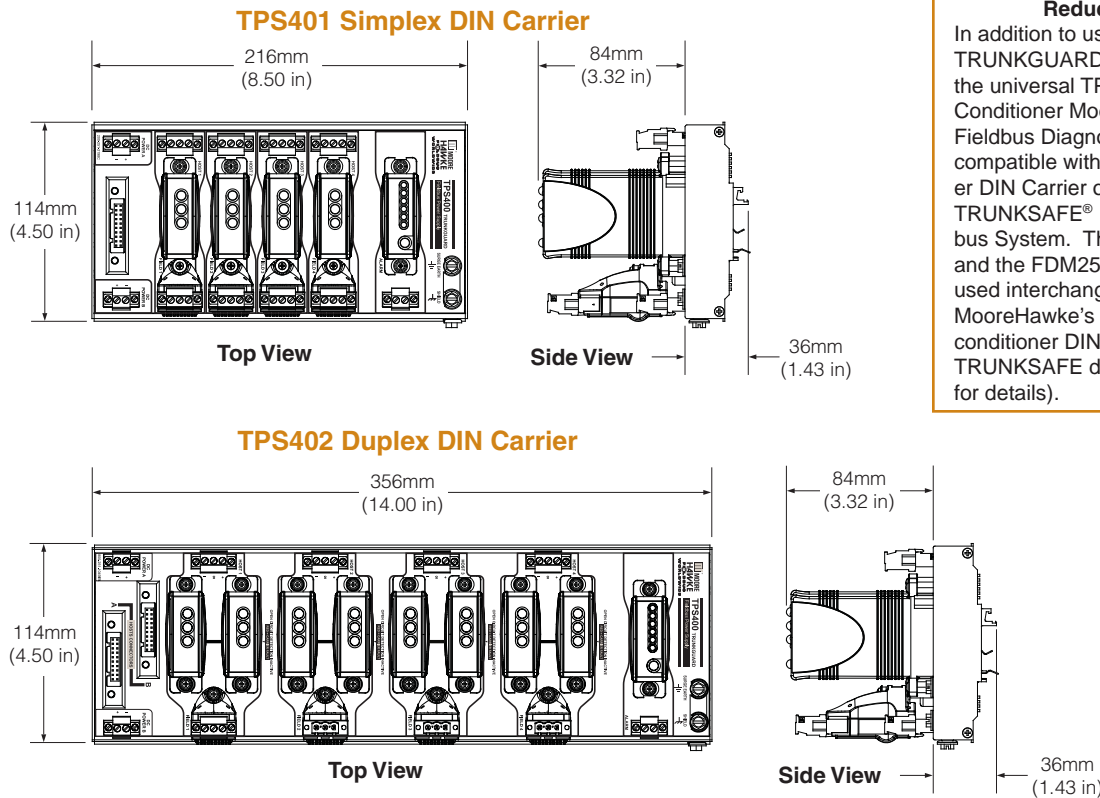

### Universal Power Conditioner and Diagnostic Modules Reduce Inventory

In addition to use with MooreHawke's TRUNKGUARD TPS400 DIN Carrier, the universal TPS202 350mA Power Conditioner Module and the FDM252 Fieldbus Diagnostics Module are compatible with the Power Conditioner DIN Carrier of the MooreHawke TRUNSAFE® Fault-Tolerant Fieldbus System. This allows the TPS202 and the FDM252 to be stocked and used interchangeably with any of MooreHawke's line of power supply/conditioner DIN carriers (see the TRUNSAFE data sheet for details).



WORLDWIDE • www.miinet.com

United States • info@miinet.com  
Tel: (818) 894-7111 • FAX: (818) 891-2816  
Australia • sales@mooreind.com.au  
Tel: (02) 8536-7200 • FAX: (02) 9525-7296

Belgium • info@mooreind.be  
Tel: 03/448.10.18 • FAX: 03/440.17.97  
The Netherlands • sales@mooreind.nl  
Tel: (0)344-617971 • FAX: (0)344-615920

China • sales@mooreind.sh.cn  
Tel: 86-21-62491499 • FAX: 86-21-62490635  
United Kingdom • sales@mooreind.com  
Tel: 01293 514488 • FAX: 01293 536852