

## DIN rail mounting safety barriers

# MTL7700 Series

## Shunt-diode safety barriers



- ◆ Removable terminals **NEW**
- ◆ Bussed power feed to other modules **NEW**
- ◆ Proximity detector inputs
- ◆ Relay and solid state switch modules **NEW**
- ◆ Dual channel variants – 6.3mm per channel **NEW**
- ◆ Electronic fusing **NEW**
- ◆ Direct replacement for MTL700 Series barriers
- ◆ Compatible terminal numbering and safety descriptions

Since its introduction in 1982 the MTL700 Series barrier has established itself as the worldwide standard for safety barriers. Known for its quality and reliability, the MTL700 Series is widely used in applications all over the world.

The MTL7700 Series follows closely in the footsteps of the MTL700 but as a DIN rail mounting barrier providing quick and easy installation without the need for special hardware.

Removable terminals are used for ease of installation, maintenance and for providing a loop disconnect by simply unplugging the terminals from the side of the module. Wire entry is also angled to assist wiring within limited space enclosures.

MTL7700 barriers clamp simply and securely onto standard T-section DIN rail, simultaneously making a reliable IS earth connection.

For applications where field power is required for switch inputs or 2-wire transmitters, the MTL7700 Series provides a bussed power feed facility. When used in conjunction with the MTL7798 power feed module the user has a fully protected, electronically fused supply to many barriers with no additional wiring required.

MTL7700 active modules are protected with an electronic fuse for the majority of applications. The MTL7798 active fused, power feed module can protect up to 40 other modules using the bussed power facility and provides a clear indication of a trip condition via a red LED.

The MTL774X range of barriers offer a NAMUR compatible input and a choice of relay or solid state output. The solid state outputs are floating so switching to ground or from a power rail into an input is also possible. The solid state interface also provides a high frequency transfer for use in flow or rotation applications.

Dual channel relay or solid state modules offer the highest packing density with only 6.3mm per channel and when used in conjunction with the power bus, offer users the minimum of wiring with the maximum packing density and the lowest cost per channel.

**SPECIFICATIONS**  
 'Key' barriers shown in blue

For notes 1 to 7 see 'Terminology' (later in this section)

Model No.	Safety description <sup>1</sup>			Polarities available <sup>2</sup>			Application	Basic circuit		Max. end-to-end resistance <sup>3</sup>	V <sub>wk</sub> at 10 (1)µA <sup>4</sup>	V <sub>max</sub> <sup>5</sup>	Fuse rating <sup>6</sup>	
	MTL	V	Ω	mA	+	-		ac	Hazardous					Safe
<b>7706+</b> <b>7707+</b>	<b>28</b>	<b>300</b>	<b>93</b>	√			<b>Transmitters</b> <b>Switches</b>	See 'HOW THEY WORK' and 'ACTIVE / ELECTRONICALLY PROTECTED BARRIERS'	See additional specification				<b>35</b> <b>35</b> <b>35</b> <b>50</b>	<b>50</b> <b>50</b> <b>50</b> <b>50</b>
<b>7707P+</b>	28 28	164 diode	171 -	√										
<b>7710+</b> <b>7715+</b> <b>7715P+</b> <b>7722+</b> <b>7728+</b> <b>7728-</b> <b>7728ac</b> <b>7728P+</b> <b>7729P+</b>	10 15 15 22 <b>28</b> 28 28 28 28	50 100 50 150 <b>300</b> 300 300 237 164	200 150 291 147 <b>93</b> 93 93 119 170	√ √ √ √ √ √ √ √ √			6V dc & 4V ac systems 12V systems 12V dc systems 18V dc systems <b>Controller outputs, solenoids</b> Transmitters Controller outputs, solenoid valves Controller outputs, solenoid valves		75 119 64 174 <b>333</b> 333 333 252 184	6.0 12.0 12.6 19.6 <b>25.9</b> 25.9 25.0 24.9 24.9	7.0 13.1 13.7 20.2 <b>26.5</b> 26.5 24.9 25.9 25.9	50 100 100 50 <b>50</b> 50 50 100 100		
<b>774X</b>	<b>10</b>	-	<b>19</b>				<b>Prox sw input, solid state output and line fault detect</b>	See 'ACTIVE / ELECTRONICALLY PROTECTED BARRIERS'	-	-	<b>30/35</b>	<b>50</b>		
<b>7755ac</b>	<b>3</b> <b>3</b>	<b>10</b> <b>10</b>	<b>300</b> <b>300</b>			√ √	<b>2 or 3- Wire (floating) RTDs</b>		<b>19.0</b> <b>19.0</b>	<b>(1)</b> <b>(1)</b>	<b>3.4</b> <b>3.4</b>	<b>250</b> <b>250</b>		
<b>7756ac</b>	<b>3</b> <b>3</b> <b>3</b>	<b>10</b> <b>10</b> <b>10</b>	<b>300</b> <b>300</b> <b>300</b>			√ √ √	<b>3 - Wire(grounded) RTDs</b>		<b>19.0</b> <b>19.0</b> <b>19.0</b>	<b>(0.7)</b> <b>(0.7)</b> <b>(0.7)</b>	<b>2.7</b> <b>2.7</b> <b>2.7</b>	<b>250</b> <b>250</b> <b>250</b>		
<b>7758+</b> <b>7758-</b> <b>7761ac</b>	7.5 7.5 9	10 10 90	750 750 100	√	√	√	Gas detectors		17 17 107	6.0 6.0 6.0	7.3 7.3 7.0	100 100 100		
<b>7761Pac</b> <b>7764+</b> <b>7764ac</b> <b>7766ac</b>	9 12 12 12	350 1k 1k 150	26 12 12 80			√ √ √ √	Strain-gauge bridges Strain-gauge bridges Strain-gauge bridges		378 1050 1050 174	6.8 10.0 10.0 10.0	7.5 10.9 10.6 10.6	50 50 50 50		
<b>7766Pac</b> <b>7767+</b> <b>7779+</b> <b>7796+</b> <b>7796-</b>	12 15 28 26 20 26 20	75 100 300 300 390 300 390	157 150 93 87 51 87 51			√ √ √ √ √	Strain-gauge bridges 12V dc systems Controller outputs Vibration probes Vibration probes	} ( 7779+ requires channels separate in IIC)	92 119 333 333 428 333 428	9.6 12.0 25.9 23.9 18.3 23.9 18.3	10.5 13.1 26.5 24.5 18.9 24.5 18.9	100 100 50 50 50 50 50		
<b>7760ac</b> <b>7765ac</b> <b>7778ac</b>	<b>10</b> 15 28	<b>50</b> 100 600	<b>200</b> 150 47			√ √ √	<b>Active dc &amp; ac sensors Thermocouples</b>			<b>75</b> 124 651	<b>6.0</b> 12.0 -0.4	<b>6.7</b> 12.5 0.4	<b>50</b> 50 50	
<b>7789+</b>	28 28 28	300 diode diode	93 <sup>a</sup> - -	√			Switch inputs / Signal returns		651 651 0.9V+26Ω 0.9V+26Ω	26.6 26.6 26.6 26.6	27.2 27.2 27.2 27.2	50 50 50 50		
<b>7787+</b> <b>7787P+</b>	<b>28</b> <b>28</b>	<b>300</b> <b>diode</b>	<b>93</b> -	√			<b>Transmitters</b> <b>Controller outputs, switches</b>		<b>333</b> <b>0.9V+26Ω</b>	<b>26.6</b> <b>26.6</b>	<b>27.2</b> <b>27.2</b>	<b>50</b> <b>50</b>		
	28 28	237 diode	119 -	√			Transmitters, Controller outputs switches		253 0.9V+21Ω	26.4 26.4	27.2 27.2	80 80		
<b>7788+</b> <b>7788R+</b>	28 10 28 10	300 50 300 50	93 200 93 200	√ √			Transmitters		333 75 333 75	25.9 6.0 25.9 -	26.5 7.0 26.5 7.0	50 50 50 50		

<sup>a</sup> Terminals 3 & 7 connected together  
 \*Diagrams show positive versions. All diodes reversed on negative versions. Additional diodes fitted on ac versions.

## HOW THEY WORK

All MTL7700 Series barriers are based on the same simple principle. Each channel contains two stages of pulse-tested Zener or forward-connected diodes and an 'infallible' terminating resistor. In the event of an electrical fault in the safe area, the diodes limit the voltage that can reach the hazardous area and the resistor limits the current. A fuse protects the diodes, and the two stages of voltage limitation ensure continued safety if either stage should fail. No active output-current limiting circuits are employed. All models are certified 'ia' for all zones and 'IIC' for all explosive atmospheres (except MTL7707P+ and MTL7729P+, 'ia' 'IIB').

## TERMINOLOGY

### 1. Safety description

The safety description of a barrier, eg '10V 50Ω 200mA', refers to the maximum voltage of the terminating Zener or forward diode while the fuse is blowing, the minimum value of the terminating resistor, and the corresponding maximum short-circuit current. It is an indication of the fault energy that can be developed in the hazardous area, and not of the working voltage or end-to-end resistance.

### 2. Polarity

Barriers may be polarised + or -, or non-polarised ('ac'). Polarised barriers accept and/or deliver safe-area voltages of the specified polarity only. Non-polarised barriers support voltages of either polarity applied at either end.

### 3. End-to-end resistance

The resistance between the two ends of a barrier channel at 20°C, ie of the resistors and the fuse. If diodes or transistors are present, their voltage drop (transistors ON) is quoted in addition.

### 4. Working voltage (Vwkg)

The greatest steady voltage, of appropriate polarity, that can be applied between the safe-area terminal of a 'basic' barrier channel and earth at 20°C for the specified leakage current, with the hazardous-area terminal open circuit.

### 5. Maximum voltage (Vmax)

The greatest steady voltage, of appropriate polarity, that can be applied continuously between the safe-area terminal of any barrier channel and earth at 20°C without blowing the fuse. For 'basic' barriers, it is specified with the hazardous-area terminal open circuit; if current is drawn in the hazardous area, the maximum voltage for these barriers is reduced. The 'ac' channels of 'basic' barriers and most channels of overvolt-protected barriers withstand voltages of the opposite polarity also – see circuit diagrams.

### 6. Fuse rating

The greatest current that can be passed continuously (for 1000 hours at 35°C) through the fuse.

### 7. Star connection

In star-connected barriers, the two channels are interlocked such that the voltage between them cannot exceed the working voltage, Vwkg: this allows for higher cable capacitance or inductance.

### 8. Maximum safe-area voltage (U<sub>m</sub>)

The maximum permissible safe-area voltage (U<sub>m</sub>) for MTL7700 Series barriers is 250V ac/dc.

## GENERAL SPECIFICATION

### Ambient temperature and humidity limits

-20 to +60°C continuous working  
-40 to +80°C storage  
5-95% RH

### Leakage current

For 'basic' barriers with a working voltage of 5V or more, the leakage current decreases by at least one decade per volt reduction in applied voltage below the working voltage, over two decades. For the MTL7755ac/7756ac it decreases by at least one decade for a 0.4V reduction in applied voltage.

### Terminations

Removable terminals accommodate conductors up to 2.5mm<sup>2</sup> (13AWG). Hazardous-area terminals are identified by blue labels. Removal force >15N

### Colour coding of barrier label

Grey: non-polarised  
Red: positive polarity (MTL7706 negative to transmitter)  
Black: negative polarity  
White: dummy barrier, MTL7799

### Weight

140g approx

### Mounting and earthing

By 35mm Top Hat DIN rail

## DIMENSIONS (mm)

### KEY MTL7700 SERIES BARRIERS SUMMARISED

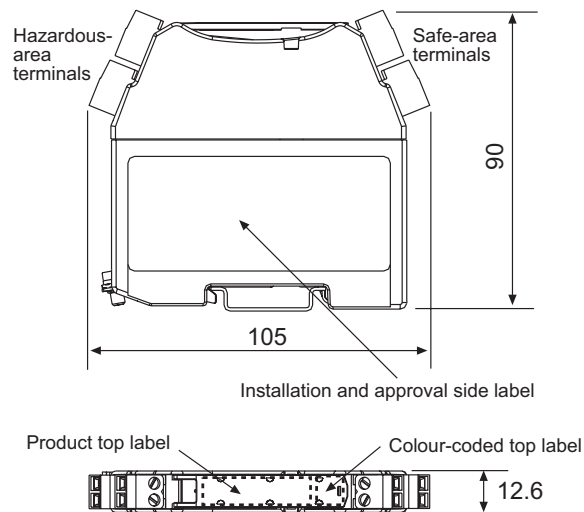

TYPE	APPLICATION	KEY BARRIER
Analogue input (low-level)	Resistance temperature detectors Thermocouples, ac sensors	<b>7756ac</b> <b>7760ac</b>
Analogue output	Controller outputs, one line earthed Controller outputs, neither line earthed	<b>7728+</b> <b>7787+</b>
Analogue input (high-level)	Transmitters, 2-wire, 4/20mA	<b>7706+</b> <b>7787+</b>
Digital (on/off) input	Switches	<b>7787+</b> <b>7741/3</b>
Digital (on/off) output	Solenoids, alarms, LEDs	<b>7728</b>

# ACTIVE / ELECTRONICALLY PROTECTED BARRIERS

## ACTIVE / ELECTRONICALLY PROTECTED BARRIERS

The following barriers have built-in overvolt protection, allowing their use with unregulated power supplies. In many applications, eg, sensor inputs or controller outputs, there is insufficient power available to blow the barrier fuse and this additional protection is not necessary. However, where the barrier is connected to a power supply, eg, for energising transmitters, switches, solenoids or local alarms, overvolt protection allows the barriers to be used with unregulated supplies and also gives protection against faulty wiring during commissioning.

### MTL7706+ for 'smart' 2-wire 4/20mA transmitters

The MTL7706+ is a 1-channel shunt-diode safety barrier, with built-in electronic overvolt protection, for energising a 2-wire 4/20mA transmitter in a hazardous area. It is powered from a positive supply of 20–35V dc and delivers a 4/20mA signal into an earthed load in the safe area. It is proof against short circuits in the field and in the safe area and is extremely accurate. The MTL7706+ will pass incoming communication signals up to 10kHz from a 'smart' transmitter, while in the outgoing direction it will pass signals of any frequency likely to be encountered.

Since the MTL7706+ has no return channel for energising the load, the entire output of the single '28V' channel is available to power the transmitter, providing high output capability. This channel is negatively polarised, and the safe-area signal is in fact the very current that returns through it from the hazardous area, the novel circuit being energised by a built-in floating dc supply derived from the external dc source of power.

To prevent any leakage through the zener diodes and maximise the output voltage available at 20mA, the floating supply is given a rising voltage/current characteristic. A separate circuit limits the current to protect the fuse in the event of a short circuit in the hazardous area. With a 20V supply, the barrier will deliver 16.2V minimum at 20mA for the transmitter and lines and consumes typically 45mA at 24V operation.

### BASIC CIRCUIT ADDITIONAL SPECIFICATION

#### Safety description

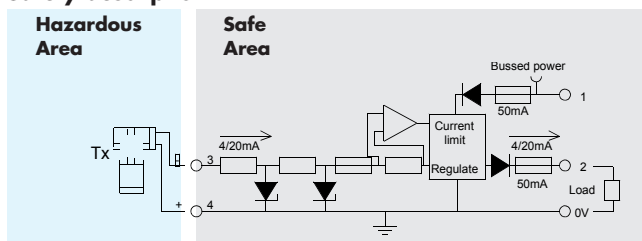

28V 300Ω 93mA

#### Supply voltage

20 to 35V dc w.r.t earth

#### Output current

4 to 20 mA

#### Voltage available to transmitter and lines

16.2V @ 20mA with 250Ω load (negative w.r.t. earth)

11.0V @ 20mA with 500Ω load (negative w.r.t. earth)

#### Accuracy

±2μA under all conditions

#### Safe-area load resistance

0 to 500Ω

#### Supply current

45mA typical at 20mA and 24V supply

60mA maximum at 20mA and 20V supply

### MTL7707+ for switch inputs and switched outputs

The MTL7707+ is a 2-channel shunt-diode safety barrier similar to the MTL7787+ but with built-in electronic overvolt protection. It is intended primarily for safeguarding a hazardous-area switch controlling a relay, opto-coupler or other safe-area load from an unregulated dc supply in the safe area.

The outgoing channel accepts supply voltages up to +35V and is protected against reverse voltages: the return channel is unaffected by voltages up to +250V.

In normal operation the protection circuit introduces only a small voltage drop and shunts less than 1mA to earth, so its overall effect is minimal. If the supply voltage exceeds about 27V, however, causing the Zener diodes to conduct – or if the safe-area load has a very low resistance – the supply current is limited automatically to 50mA, protecting the fuse and power supply and enabling the loop to continue working.

### BASIC CIRCUIT

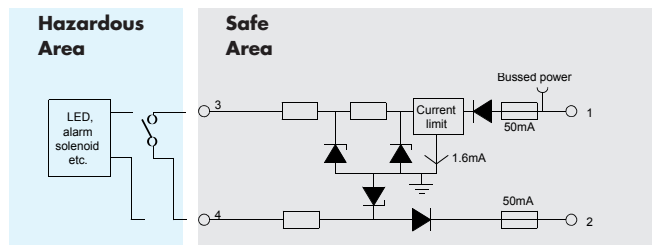

### ADDITIONAL SPECIFICATION

#### Safety description

28V 300Ω 93mA, terminals 1 to 3

28V Diode, terminals 2 -4

#### Supply voltage

10 to 35V dc with respect to earth

#### Output current

Up to 35mA available

#### Maximum voltage drop

(at 20° C, current not limited)

$I_{out} \times 332.5\Omega + 0.3V$ , terminals 1 to 3

$I_{out} \times 25.9\Omega + 0.9V$ , terminals 4 to 2

#### Supply current

$I_{out} + 1.6mA$ , supply <26V

Limited to 50mA, supply >28V or low load resistance

### MTL7707P+ for switch inputs and switched outputs, 2W Transmitters (IIB gases)

The MTL7707P+ is a two-channel shunt-diode safety barrier similar to the MTL7787P+, but is designed for use with group IIB gases and features built-in electronic overvolt protection allowing use with unregulated power supplies up to 35V dc. It is intended primarily as a low cost solution for driving IIB certified 2-wire 4/20mA transmitters, but can also be used with controller outputs with current monitoring, solenoid valves and switches. To protect the fuse and enable the loop to continue working, the supply current is limited automatically at 50mA should the output be short-circuited or excess voltage applied.

## BASIC CIRCUIT

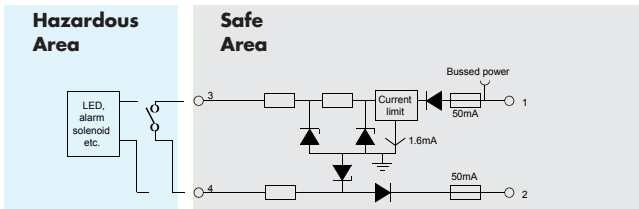

## ADDITIONAL SPECIFICATION

### Safety description

28V 164Ω 171mA, terminals 1 to 3  
28V Diode, terminals 4 to 2

### Supply voltage

10 to 35V dc with respect to earth

### Output current

Up to 35mA available

### Maximum voltage drop

#### (at 20C, current not limited)

$I_{out} \times 204.5\Omega + 0.3V$ , terminals 1 to 3  
 $I_{out} \times 21.1\Omega + 0.9V$ , terminals 4 to 2

### Supply current

$I_{out} + 1.6mA$ , supply <26V  
Limited to 50mA, supply >28V or low load resistance

## MTL7741 proximity sensor or switch input and relay output

The MTL7741 is a single channel switch/prox input barrier with changeover relay contacts acting as the safe area interface. Relay contacts provide a universal interface capable of switching a wide range of signals including ac, low level and high level voltages. Phase reversal is achieved by connecting the normally open or normally closed contacts as required. The power bus terminal may be used to connect the module to a power source.

## BASIC CIRCUIT

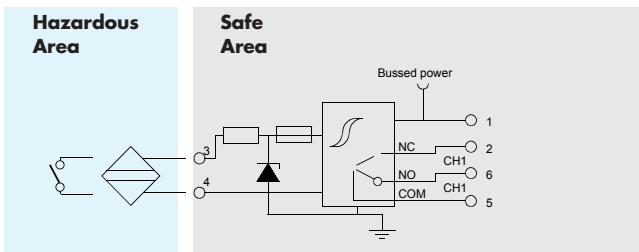

## ADDITIONAL SPECIFICATION

### Safety description

10V 19mA

### Supply voltage

22.9 to 30V dc with respect to earth

### Input characteristics

Relay energised if input >2.1mA (<2kΩ)  
Relay de-energised if input <1.2mA (>10kΩ)

### Relay Contacts

\*125V ac 0.5A. Resistive  
30V dc, 1A. Resistive

### Supply current

26mA maximum @ 24V

### Response time

<10ms

\* There are limitations for use above 50V. Please refer to the Instruction Manual INM7700.

## MTL7742 proximity sensor or switch input with solid state output

The MTL7742 is a single channel switch/prox input barrier with an open collector solid state interface to the safe area equipment. The solid state switch is especially useful for high frequency switching apparatus including pulse and rotational sensors. The power bus terminal can be used to connect power to the module and the input power supply range makes the module suitable for use with unregulated supplies

## BASIC CIRCUIT

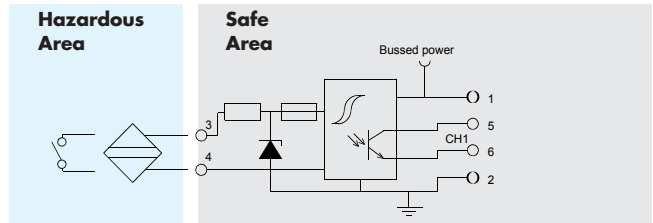

## ADDITIONAL SPECIFICATION

### Safety description

10V 19mA

### Supply voltage

20 to 35V dc with respect to earth

### Input characteristics

Output energised if input >2.1mA (<2kΩ)  
Output de-energised if input <1.2mA (>10kΩ)

### Output characteristics

Operating frequency dc to 2.5kHz  
Max off-state voltage 35V  
Max off-state leakage 10μA  
Max on-state voltage drop <1.41V @ 50mA  
<1.22V @ 2mA  
typically <1V  
Max on-state current 50mA

### Supply current

20mA maximum @ 24V

## MTL7743 2 channel proximity sensor or switch input and relay outputs

The MTL7743 is a dual channel switch/prox sensor input barrier with a relay interface. This module is ideal for applications where high channel packing densities are required for digital inputs. Power is connected using the power bus terminal.

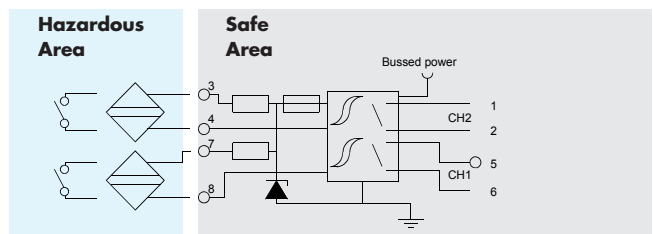

## BASIC CIRCUIT

## ADDITIONAL SPECIFICATION

### Safety description

10V 19mA

10V 19mA

### Supply voltage

22.9 to 30V dc with respect to earth

### Input characteristics

Relay energised if input >2.1mA (<2kΩ)  
Relay de-energised if input <1.2mA (>10kΩ)

### Relay Contacts

\*125V ac 0.5A. Resistive  
30V dc, 1A. Resistive

### Supply current

45mA maximum @ 24V

### Response time

10ms

## MTL7744 2 channel proximity sensor or switch inputs with solid state outputs

A dual channel version of the MTL7742, this module provides two solid state interfaces for prox/switch inputs. Power is connected via the power bus.

### BASIC CIRCUIT

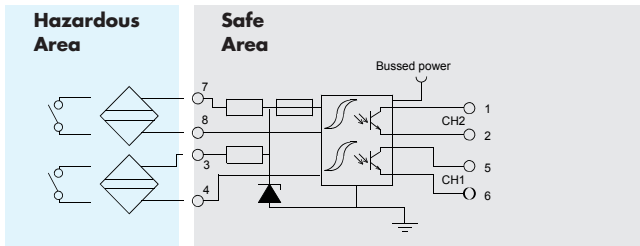

### ADDITIONAL SPECIFICATION

#### Safety description

10V 19mA  
10V 19mA

#### Supply voltage

20 to 35V dc with respect to earth

#### Input characteristics

Output energised if input  $>2.1\text{mA}$  ( $<2\text{k}\Omega$ )  
Output de-energised if input  $<1.2\text{mA}$  ( $>10\text{k}\Omega$ )

#### Output characteristics

Operating frequency	dc to 2.5kHz
Max off-state voltage	35V
Max off-state leakage	10 $\mu$ A
Max on-state voltage drop	1.41V @ 50mA 1.22V @ 2mA typically $<1\text{V}$
Max on-state current	50mA

#### Supply current

29mA maximum @ 24V

## MTL7745 proximity sensor or switch input with relay output and line fault detect

The MTL7745 is a single channel switch/prox input barrier providing line fault detection. Proximity detectors or switches fitted with end-of-line resistors may be connected. Short circuit or open circuit conditions in the field wiring will generate an alarm condition. The LFD relay contacts close when a fault is detected allowing the contacts to be connected in parallel to provide a common alarm. The power bus terminal can be used to connect power to this module.

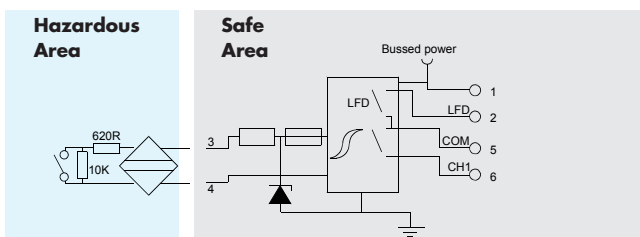

### BASIC CIRCUIT

### ADDITIONAL SPECIFICATION

#### Safety description

10V 19mA

#### Supply voltage

22.9 to 30V dc with respect to earth

#### Input characteristics

Output energised if input  $>2.1\text{mA}$  ( $<2\text{k}\Omega$ )  
Output de-energised if input  $<1.2\text{mA}$  ( $>10\text{k}\Omega$ )

#### LFD relay + Red LED

Energised if input  $<50\mu\text{A}$  or  $<100\Omega$

### Relay contacts

\* 125V ac 0.5A. Resistive  
30V dc, 1A. Resistive

### Supply current

38mA maximum @ 24V

### Response time

$<10\text{ms}$

## MTL7798 Power feed and protection module

The MTL7798 power feed module incorporates both voltage and current sense mechanisms to protect barrier circuits by activating a solid state trip mechanism when fault or overload conditions occur in the power source circuit. Resetting the module after tripping is achieved by interrupting the supply to the unit. A red LED indicates a circuit trip condition and a green LED the availability of power at the outputs. Bussed power for other modules is sourced from the top of the unit using the Bus Power Link BPL7700 or via terminals 1 and 2.

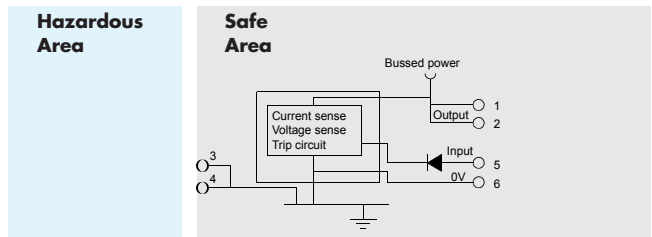

### BASIC CIRCUIT

### ADDITIONAL SPECIFICATION

#### Input voltage range (terminals 5&6)

20 to 26.8V

#### Maximum input voltage capability

45V

#### Power source requirements

$>1.8\text{A}$

#### Trip mechanism

Minimum trip 26.8V @ 20°C (+18mV/°C)

#### Output current range

0 to 800mA

#### Maximum voltage drop

20mV @ 0mA, 1.0V @ 800mA load

\* There are limitations for use above 50V. Please refer to the Instruction Manual INM7700.

# MTL7700 SERIES BARRIER APPLICATIONS

MTL7700 Series barriers protect devices located in all normally occurring explosive atmospheres, including air/flammable gas mixtures, dusts and fibres. Applications covered include the protection of installations incorporating uncertified devices ('simple apparatus') such as thermocouples, switches and resistive sensors, or separately certified 'energy storing' (or 'voltage producing') apparatus including ac sensors, transmitters and current-to-pneumatic (I/P) converters. Recommended choices for specific applications are discussed briefly in the following pages.

## ANALOGUE INPUTS (HIGH LEVEL)

### 2-wire transmitters, 4/20mA, conventional and smart

The recommended barrier for use with 'conventional' and 'smart' 4/20mA transmitters (fed by a 26V regulated supply) is the MTL7787+. This provides up to 12.9V (14.6V for MTL7787P+) at Vwkg and 20mA for a transmitter and its lines as well as 5V for the typical 250Ω load. This application and this barrier is suitable for use with the optional power bus facility.

The MTL7706+ is recommended for applications where an unregulated supply of up to 35V is used. It provides 16.0V for transmitter and lines at 20mA as well as 5V for a typical 250Ω load. With the MTL7706+ terminal 3 is negative with respect to earth, so the connections to terminals 3 and 4 should be reversed.

### Vibration probes

The 3-wire transmitters used with vibration monitoring equipment are invariably supplied by a -24V dc power supply - hence the recommended barrier choice is the negatively-polarised MTL7796-.

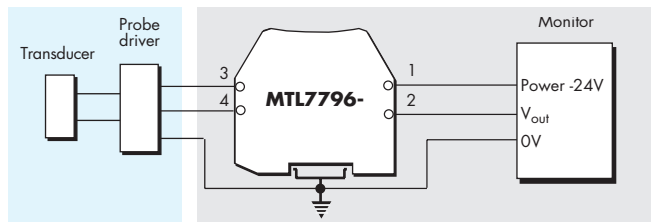
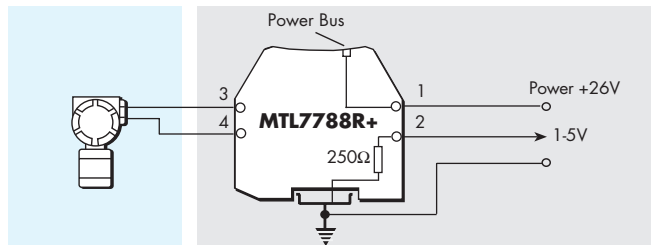
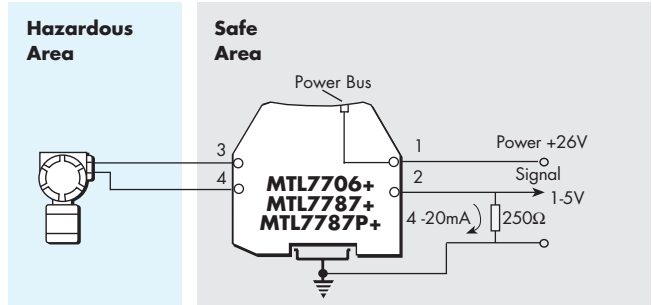

## ANALOGUE INPUTS (LOW-LEVEL)

### Thermocouples and mV sources

The recommended barrier for thermocouples and mV sources is the MTL7760ac. This 2-channel non-polarised barrier retains the 'earth-free' nature of the signal and, providing the receiver's input 'floats', rejects common-mode ac and dc interference up to at least 7V and is unaffected by earth faults on the primary element.

### ac sensors, photocells, microphones and turbine flowmeters

The MTL7760ac is the recommended choice for these devices. While many of these are designated 'simple apparatus' and thus do not need certification, note that some ac sensors may be subject to a significant level of inductance and will therefore need to be designed and certified for hazardous-area locations.

### Slidewire displacement transducers

The simplest choice is the MTL7760ac. This barrier supplies power and brings back a unipolar signal.

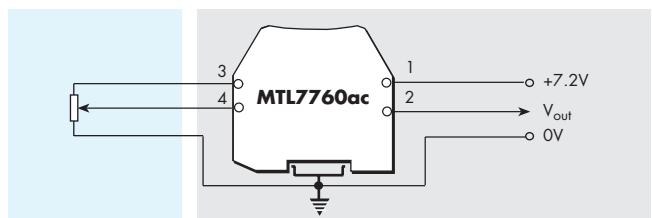
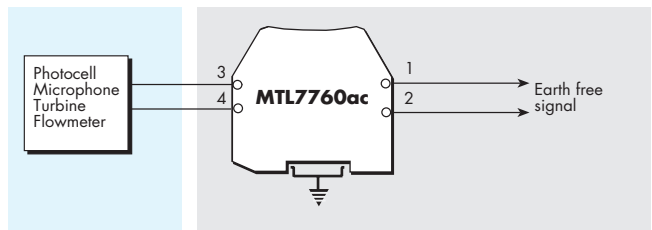
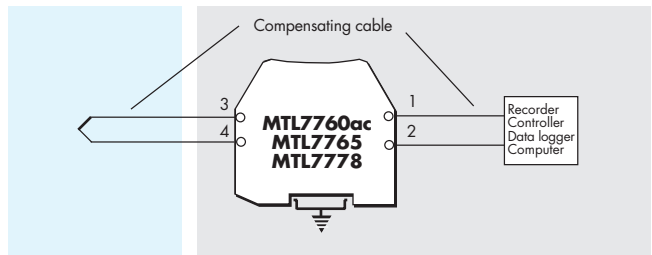

## RTDs

For 3-wire RTDs, a single MTL7755ac barrier is the most economical choice. This is suitable for use with a floating bridge – the two leads from the bridge arms are protected by the barrier with the third (supply) lead being earthed through the barrier. The barrier has a low end-to-end resistance of only  $19\Omega$ /channel to minimise span changes and its channels track within  $0.15\Omega$  (between  $-20$  to  $+60^\circ\text{C}$ ) to minimise zero shift with temperature.

If the bridge circuit is already earthed, the third barrier channel provided by an MTL7756ac is needed. For extreme accuracy, 3 channels and an earth-free bridge can be used, a configuration that cancels out the small errors due to barrier leakage. Channels 1 and 2 (those between terminals 1 & 2, and 2 & 4 respectively) track to within  $0.15\Omega$  between  $-20$  and  $60^\circ\text{C}$ .

4-wire constant-current circuits do not need matched barrier resistances and can be protected by two MTL7761ac barriers. If the increase in loop resistance is too great, use two MTL7755ac barriers instead.

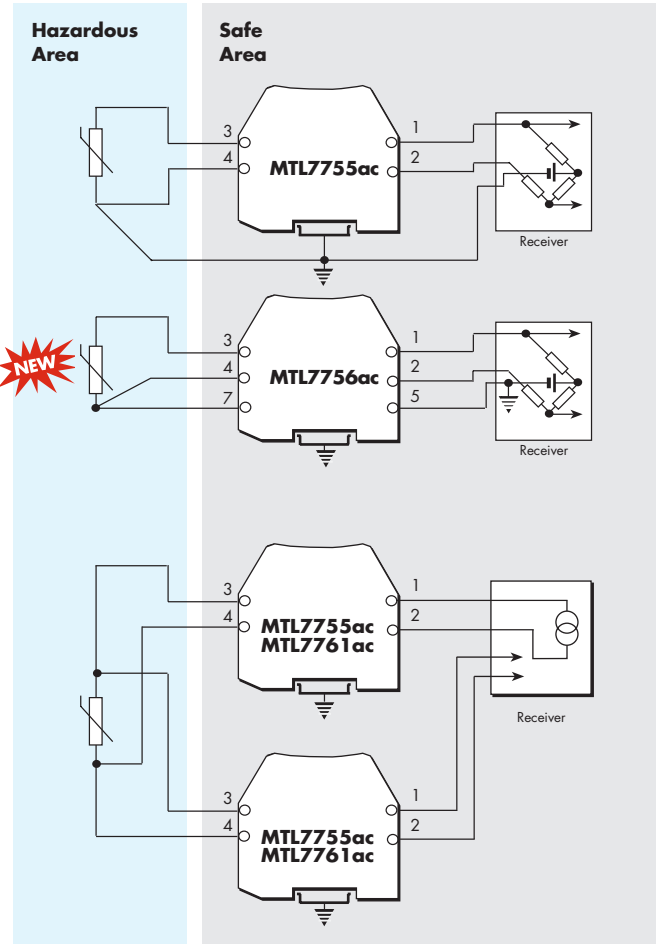

## STRAIN-GAUGE BRIDGES

### Single strain-gauge bridges

This shows an arrangement using two or three barriers, which is safe in IIC gases. With the MTL7761ac, the circuit is powered from a  $14\text{V}$ ,  $230\Omega$  source; if the bridge resistance is  $230\Omega$ , then the bridge voltage is  $7\text{V}$ . If the bridge resistance is  $350\Omega$ , then the bridge voltage is  $8.4\text{V}$ .

An MTL7764ac can be used to sense the bridge supply voltage.

An MTL7761ac is used here for the mV output.

An MTL7766Pac provides  $12.3\text{V}$  for a  $350\Omega$  bridge with a  $20\text{V}$  supply. MTL7761Pac's can be used for the sense and pick-off circuits.

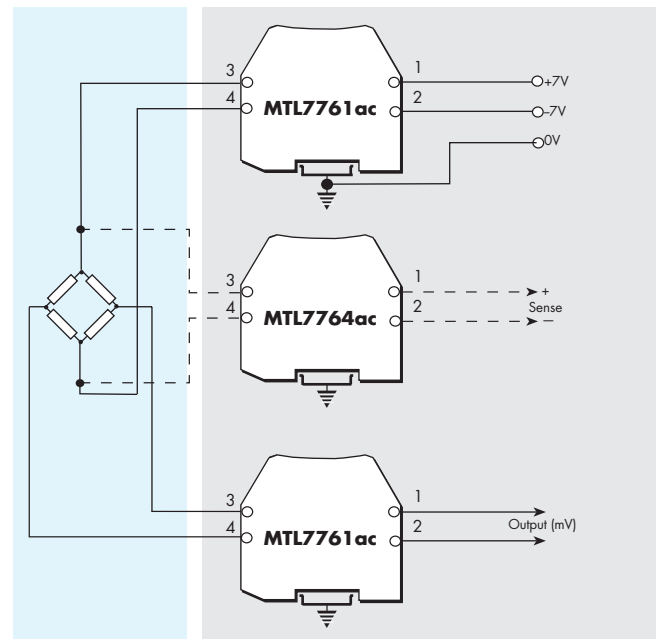

## STRAIN-GAUGE BRIDGES (cont)

### Double strain-gauge bridges

Quite frequently there is a demand to monitor two load cells, and a possible circuit, safe in IIC, is shown.

Here, the lower voltage drop of the MTL7766Pac is an advantage.

The MTL7766Pac supplies power to the bridge(s) whilst two MTL7761Pac barriers interface with the sense and pick-off circuits.

Using 350Ω bridge systems, the following voltages are available from an MTL7766Pac with a ±10V supply:

1 bridge: 13.11V

2 bridges: 9.75V

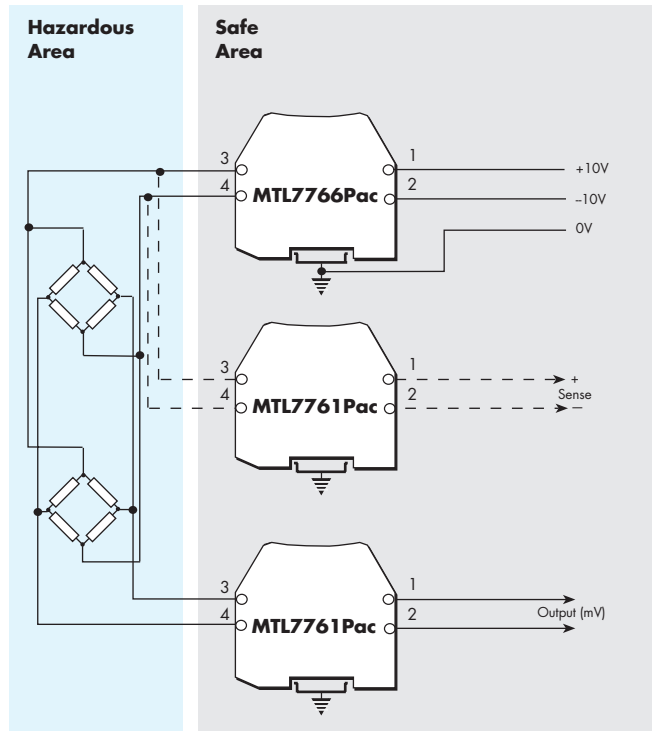

## ANALOGUE OUTPUTS

### Controller outputs (I/P converters)

The single-channel MTL7728+ with a voltage drop of 6.66V is the recommended choice for most controller outputs. Higher-power versions are available: the MTL7728P+ (5.1V drop) is suitable for IIC applications; the MTL7729P+ (3.68V drop) for IIB applications.

For controllers with an output circuit separated from the 0V rail by the control transistor, the 2-channel MTL7787+ is the preferred choice as the return channel can handle up to 26.6V allowing the control signal to be turned off completely. The voltage drop is 8.1V at 20mA. A higher-power version of the latter, the MTL7787P+, is also available. The return channel of these barriers handle up to 26.4V and the maximum voltage drop is only 6.38V

The MTL7787+ and MTL7787P+ are also suitable for controllers containing a resistor which enables the return current to be monitored for high-integrity operation.

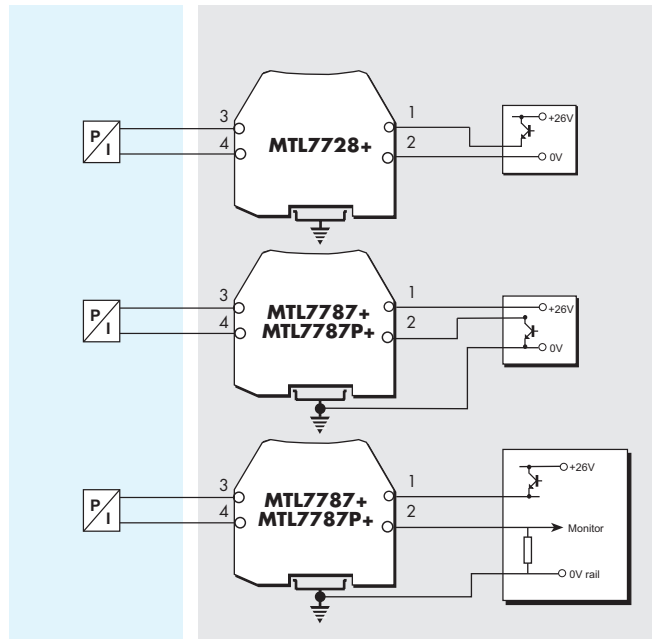

## DIGITAL (ON/OFF) INPUTS

### Switches

The normal choice is the MTL7787+/7787P+ with a regulated supply. The MTL774X modules are recommended for applications where an unregulated supply of up to 35V is used.

The MTL7789+ offers a dual channel passive barrier for switch inputs where the input current for each channel is <10mA.

### Switches / Proximity detectors

MTL's range of new switch/prox input barriers provide the user with a choice of relay and solid state outputs in single and dual channel versions.

The MTL7741 is single channel with a changeover relay output.

The MTL7742 has a single channel solid state switch that can be configured to switch from a power rail or down to ground. This is also ideal for high switching frequency applications.

The MTL7743 and MTL7744 are dual channel versions affording very high packing densities. Power must be provided to these modules using the power bus facility.

The MTL7745 is a single channel proximity input (or switch input if 'end of lines' resistors are fitted) with relay contacts providing switch and line fault status. The LFD relay contacts close when a fault is detected.

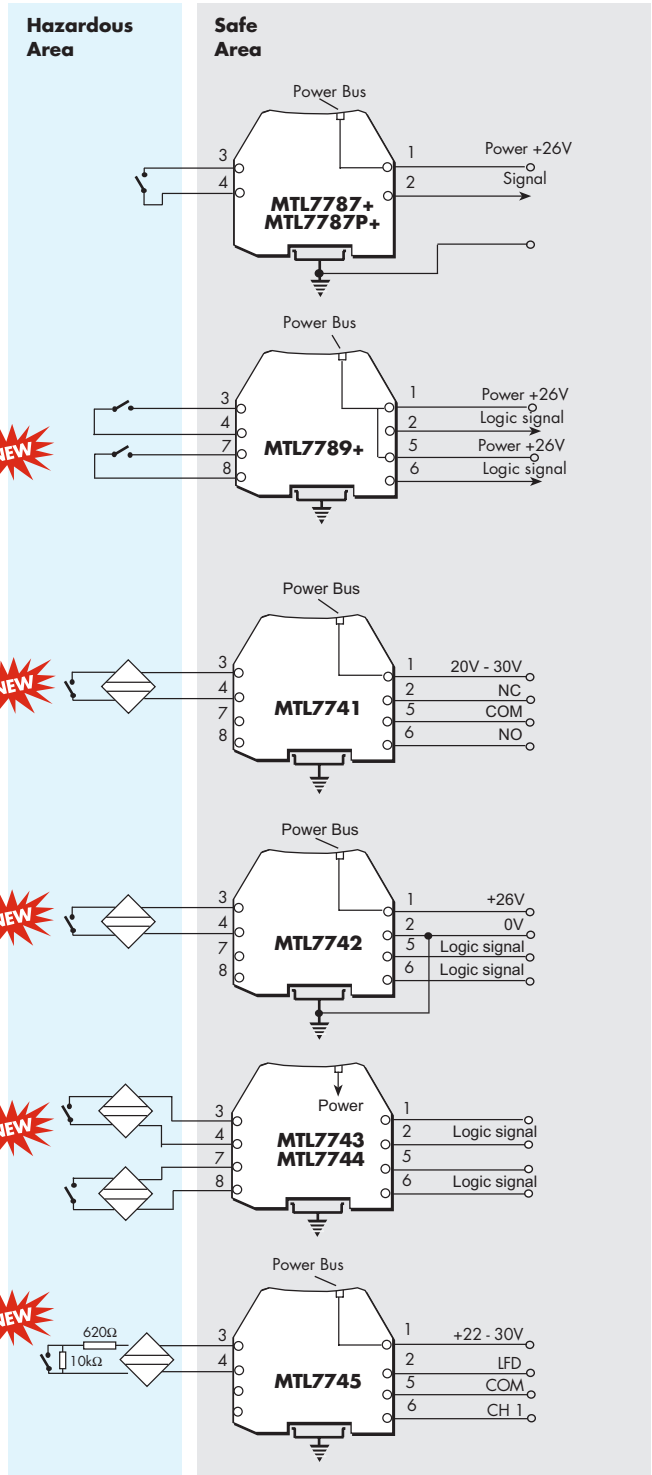

## DIGITAL (ON/OFF) OUTPUTS

### Alarms, LEDs, solenoids valves, etc

For these applications, the MTL7728+ is recommended. Higher-powered versions are available: the MTL7728P+ is suitable for IIC applications; the MTL7729P+ for IIB applications.

If the control switch is to earth, then the 2-channel MTL7787+ barrier should be used, or, alternatively, the MTL7787P+ higher-power version. If the supply is poorly regulated use the MTL7707+.

The MTL7707+ is recommended for applications where an unregulated supply of up to 35V is used.

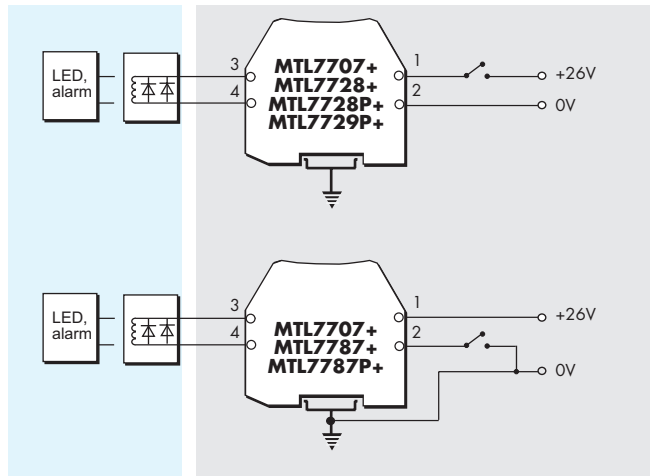

## +VE DC SYSTEMS

### Low-level to 12V dc systems

The two channels of the MTL7764+ and MTL7767+ can be combined safely in IIC.

The MTL7764+ can be used for low-level logic return signals whilst the MTL7767+ is used for 6V dc and 12V dc systems.

### 18V dc systems

The single-channel MTL7722+ is recommended for 18V dc systems.

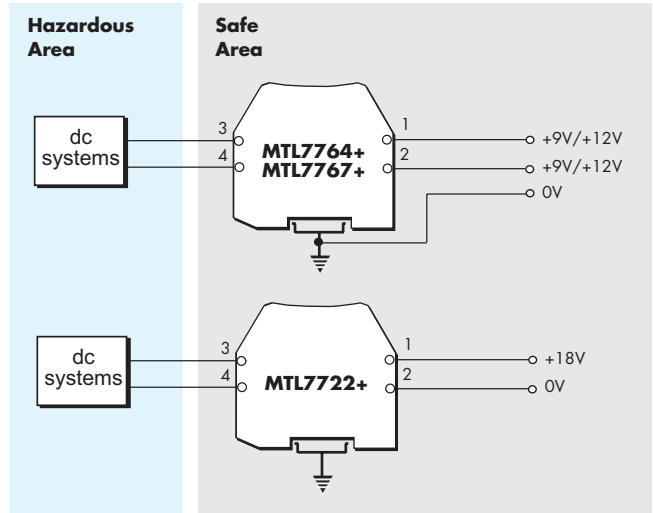

## AC AND DC SYSTEMS

### High-level ac and dc systems

The versatile star-connected MTL7765ac and MTL7778ac allow  $V_{wkg}$  to be developed from each channel to ground but only allow  $V_{wkg}$  to be developed between channels. This provides some common-mode voltage capability and can allow higher cable parameters to be used.

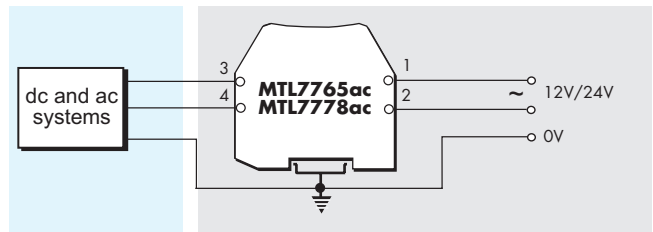

## NEGATIVE AND FLOATING POWER SUPPLIES

### Digital (on/off) outputs

The MTL7728- is used with a negative power supply and positive earth. Typically used for digital inputs or outputs, as shown.

The MTL7728- can also be used with floating power supplies, for transmitters.

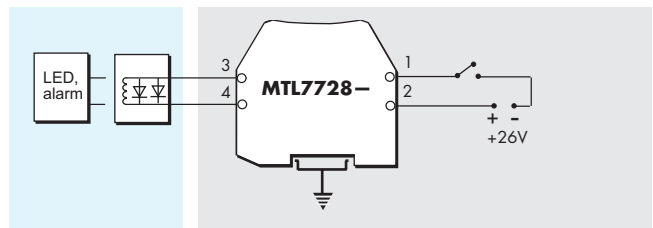

## SPARE CABLE CORES AND SCREENS

The MTL7799 dummy barrier is used primarily for securing and earthing unused cables and screen connections. Hazardous area terminals 3 and 4 are internally connected to the DIN-rail mounting/earth connection. It also provides a power bus connection for direct connection of power for modules such as the MTL7743 and MTL7744 where no power supply screw terminal is provided.

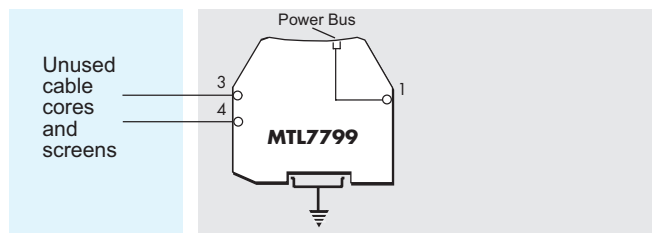

## POWER BUS APPLICATIONS



The PB7700 power bus is invaluable for saving installation time and wiring when connecting a 24V dc power source to a number of barriers.

Typical applications include hazardous-area switches, 4/20mA transmitters and proximity detectors. The diagram illustrates the configuration for 4 barriers but up to 40 barriers can be served by this method.

The MTL7798 power feed module would normally be used with standard barriers such as MTL7787+ and MTL7787P+ because the current/voltage trip protection mechanism of the MTL7798 protects the fuses in the barriers.

The MTL7799 dummy barrier can be used instead of the MTL7798 for direct 'feed-through' connection of a 24V dc supply. Looping the power feed to each end of the bussed power allows the removal of individual barriers without loss of power to others in the chain.

Other units which can use the power bus facility:

- MTL7706
- MTL7707+
- MTL7707P+
- MTL7741
- MTL7742
- MTL7743
- MTL7744
- MTL7745
- MTL7787+
- MTL7787P+
- MTL7788+
- MTL7788R+
- MTL7789+

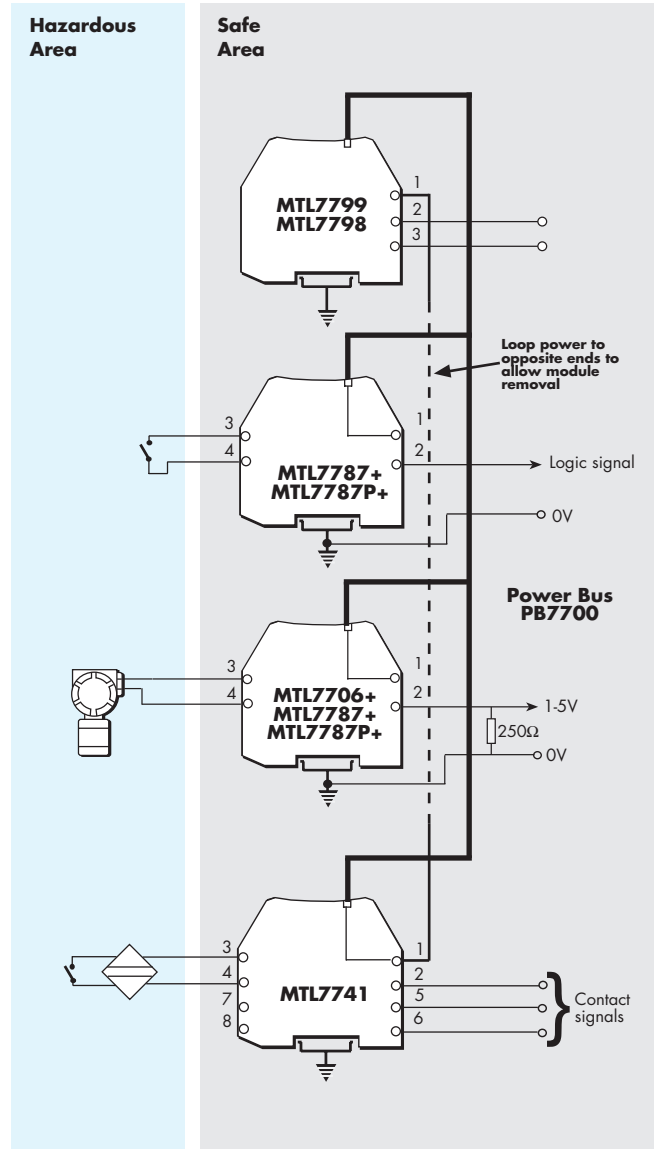

# MTL7700 SERIES ACCESSORIES

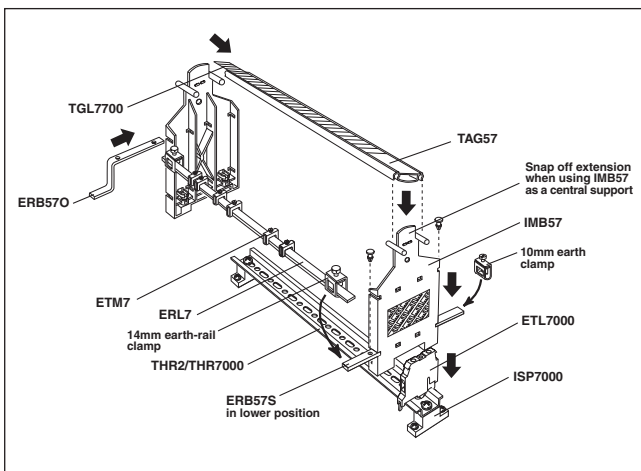

## MOUNTING/EARTHING ACCESSORIES

MTL7700 Series barriers mount easily and quickly onto standard DIN rail which also acts as the intrinsically safe earth.

### THR2 standard DIN rail THR7000 plated rail

Specially nickel-plated T-section (35mm x 7.5mm) DIN rail for use in potentially corrosive atmospheres. Supplied in 1 meter lengths.

### ISP7000 insulating spacers

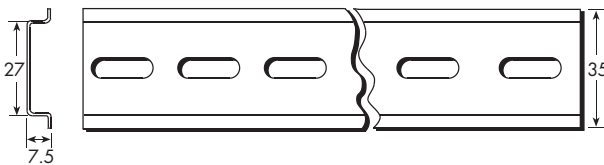

Attached to the base of a DIN rail at either end or at intervals (depending upon DIN rail length) to isolate the IS earth from a structural earth.

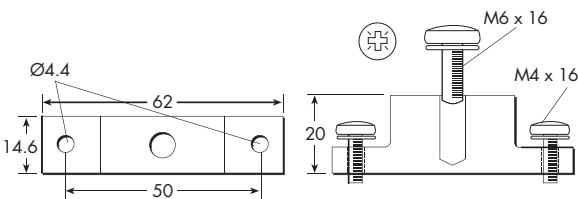

### ERB57S Earth-rail bracket, straight

Nickel-plated; supplied with two push fasteners, one 14mm earth-rail clamp and one 10mm earth clamp for cables  $\leq 16\text{mm}^2$ .

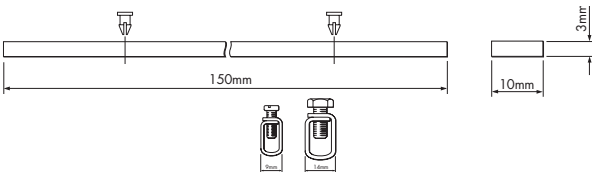

### ETM7 earth terminal

For terminating cable screens and 0V earth returns and securing spare cores to the earth rail. A maximum of one ETM7 per barrier can be



### IMB57 Insulating mounting block

One required at each end of a tagging strip/earth rail. Suitable for low-profile (7.5mm) and high-profile (15mm) symmetrical DIN rail.

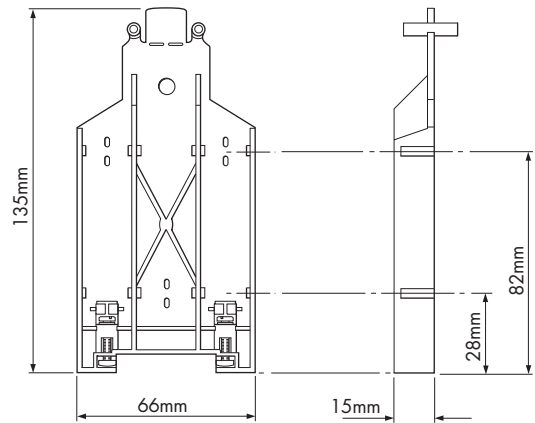

### ERB570 Earth-rail bracket, offset

Nickel-plated; supplied with two push fasteners, one 14mm earth-rail clamp and one 10mm earth clamp for cables  $\leq 16\text{mm}^2$ .

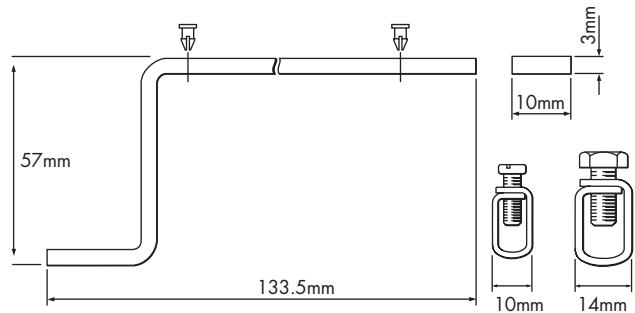

### ETL7000 earth terminal

Provides connection for routing the IS earth from the DIN rail to an appropriate plant earth. Maximum cable cross-section is  $10\text{mm}^2$ . Two recommended per discrete length of DIN rail. See instruction manual INM7700 for more details.

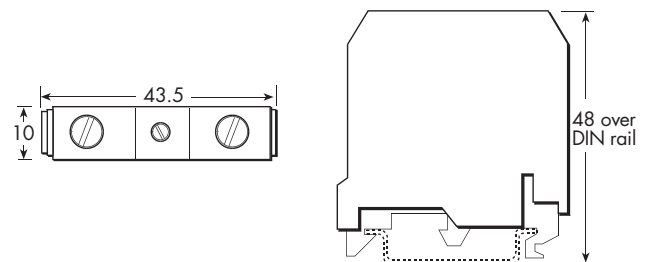

### BPL7700 Power Bus link

When a number of barriers use a common power supply, the optional power link (BPL7700) can be used. Typical applications include hazardous area switches, solenoids and 4–20mA transmitters; and the barriers it can be used with are the MTL7706, MTL7707+, MTL7787+, MTL7787P+ and MTL774X.



## TAGGING ACCESSORIES

Two methods of tagging are available which can be used separately or together:

1) **Individual barrier identification  
TH7700 barrier identifiers**

TH7700 barrier identifiers are supplied clipped on to the tops of individual barriers to provide transparent holders for identification labels.

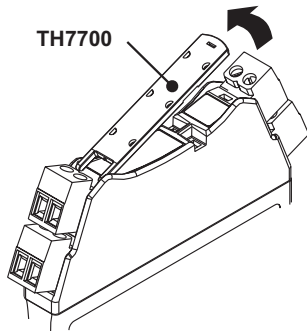

2) **Tagging strip method  
TAG57 Tagging strip, 1m length**

Cut to size. Supplied with reversible tagging strip label suitable for either MTL5000 or MTL7000 Series module spacing.

**TGL7700 Tagging strip labels, set of 10 x 0.5m**

For use with TAG57 tagging strip. Tags are reversible - one side for MTL7700, the other for MTL700.

## HOW TO ORDER

### MTL7700 barriers

Select by barrier number and polarity,  
e.g. MTL7728+

### Mounting accessories

THR2	Standard DIN-rail, 35 x 7.5mm
THR7000	T-section DIN-rail, specially-plated, 35 x 7.5mm, 1m length
ISP7000	Insulating spacer

### Standard earthing/earth-rail accessories

ETL7000	Earth terminal, DIN-rail mounted
IMB57	Insulating mounting block
ERB57S	Earth-rail bracket, straight
ERB57O	Earth-rail bracket, offset
ERL7	Earth rail, 1m length
ETM7	Earth terminal, pack of 50

### Standard tagging accessories

TAG57	Tagging strip, 1m length
TGL7700	Tagging strip labels, set of 10 x 0.5m

### Bussed power links

BPL7700	Pack of 100
---------	-------------

### Enclosures

DX070	Enclosure, for MTL7700 x 5
DX170	Enclosure, for MTL7700 x 13
DX430	Enclosure, for MTL7700 x 33

### Spares

SAF7712	Safe-area terminals 1&2
HAZ7734	Hazardous area terminals 3&4
SAF7756	Safe-area terminals 5&6
HAZ7778	Hazardous area terminals 7&8
TH7700	Tag holder

### Literature

INM7700	Instruction manual, MTL7700 Series
INM57ENC	Instruction manual, MTL5000/7000 Series Enclosures
CD7700...	Customer drawings