

Alphanumeric
displays in
hazardous areas

MTL643/644 DISPLAYS

IS text displays



- ◆ **Large LCD alphanumeric display**
- ◆ **Point to point or multidrop communication with PC, PLC or simple host**
- ◆ **RS232 or RS422 in safe area**
- ◆ **Easy to configure simple ASCII communication**
- ◆ **Tough impact-resistant field unit with separate terminal compartment**
- ◆ **DIN-standard panel-mounted version**

The **MTL642/644 IS text displays** are located in the hazardous area where they display alphanumeric data from a safe-area host controller. This is transmitted by a serial data link passing through an MTL5051 isolating interface. This serves the dual purpose of isolating the IS indicator and converting RS232 or RS422 serial data to the MTL signal level and vice versa. Bi-directional communication permits operators to acknowledge messages and to request process action when necessary. If required, an audible or visual alarm can be connected to attract the operators attention.

A **clear and unambiguous alphanumeric display** is provided by liquid crystal module with two lines of up to sixteen 9mm high characters. All 32 characters may be alphanumeric so process values, engineering units, tag idents and operator messages are easily displayed.

Operator control is provided by three external switches (not supplied) which are connected to terminals on the indicator and which can be used to acknowledge alarm messages and change process information such as the resetting of the tare in a weighing system.

The **controller** maintains master control, requiring all remote display units to respond to its commands. In multi-indicator applications, it transmits a block of information which includes the indicator type, address and data. Data is transmitted in the form of ASCII characters interpreted by the appropriate indicator which either updates the display or responds with a reply such as indicator status or switch status.

In **single indicator applications**, the protocol may be simplified to direct data transmission for communication with less sophisticated host units including PLCs, dedicated control instrumentation and weighing systems.

A **single alarm output** (an opto-isolated open collector transistor output) is provided for connection to a suitable visual or audible alarm unit to attract the operator's attention.

Error checking routines are carried out by the indicator, the result being stored in the status data register where it can be accessed by the host computer.

MTL643 field mounting unit is housed in a tough impact-resistant GRP case designed to withstand the rigours of hostile weather conditions and harsh industrial environments. Ingress protection rating is IP66. It can be mounted directly onto a flat surface or with an optional PIP68 kit, onto vertical or horizontal pipes or posts.

MTL644 panel mounting unit is designed for DIN standard 72 x 144mm casing. The cut-out size will depend on the rating required. The front panel fascia is protected to IP65 while, with standard 'snap-on' mounting clips, the panel/unit seal is rated IP40. This can be upgraded to IP65 with the optional IPK68 sealing kit. For mounting details see MTL680.

SPECIFICATION

Location

Zone 0, IIC, T4, hazardous area
Div. 1, Group A, hazardous area

Power supply

9 to 28V at 8mA, through interface or from IS supply.

Display

2x16 character alpha-numeric lcd display; 9 mm characters, 5x7 dot matrix.

Display characters

ASCII character set plus 8 computer-defined soft characters.

Cursor position

Host computer controlled, visible or invisible on display.

Controls

Terminals provided for connecting three external switches for operators to acknowledge messages or initiate process changes; maximum cable length 5m.

Alarm

One opto-isolated open collector transistor to operate visual or audible alarm.

External power supply required.

Transistor spec: open-circuit voltage <28V
short-circuit current -50mA(<2V drop at 50mA)

IS interface

MTL5051 Serial data communications isolator converts RS232/RS422 to MTL serial data format

One interface unit can power up and pass data to one or two indicators

One interface unit can pass data to up to four indicators provided power is supplied by a MTL5025 IS remote source

Data link

Single data highway from IS interface unit, half duplex

Host controller format

RS232 or RS422.

Multi-indicator configurations communicate according to MTL serial data protocol (see publication INM643).

Single indicator configurations can communicate by a direct ASCII data pattern (indicator address set at 0).

System protocol

Transmission based on blocks of information using printable ASCII characters; full MTL system protocol software provided in publication INM643.

Transmission speeds and format (DIL switch selectable)

1.2, 2.4, 4.8, or 9.6kbaud

1 or 2 stop bits

odd, even, or no parity bit

7 or 8 data bits

Note: Combinations of 8 bits, 2 stop bits, parity bit and 7 bits, 1 stop bit, no parity are not permitted

Terminals

For conductors up to 2.5mm²

Safety descriptions

<28V, <1.2W, <200mA

Weight

MTL643 approximately 1.3 kg

MTL644 approximately 275 g

Ambient temperature

0 to +50°C working

-20 to +70°C storage

Humidity

0 to 95% non-condensing

Dimensions and mounting details

MTL643 see MTL680 Series field-mounting indicators page for details

MTL644 see MTL680 Series panel-mounting indicators page for details

SYSTEM CONFIGURATIONS

MTL643 or MTL644* Signal powered

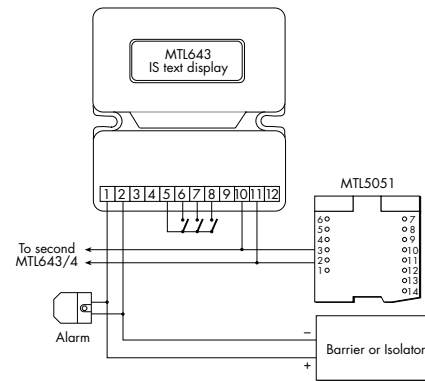

* With MTL644 connections are from 5051 to PL1 terminals 2 and 3 and the optional alarm is connected to PL2 terminals 1 and 2

MTL643† or MTL644 Separately powered

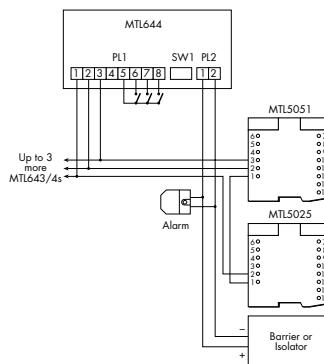

† With MTL643 connections are from 5051/5025 to terminals 10, 11 and 12 and the optional alarm is connected to terminals 1 and 2

APPROVALS

Country (Authority)	Standard	Certificate/file no.	Approved for
Australia (SA)	AS2380.7	*	Ex ia IIC T4
Canada (CSA)	C22.2 No.157	*	Class I, Div. 1, Gps. A-D T4
Czech Republic (FTZU)	EN 50014 & EN 50020	99Ex0226	II 2 G EEx ia IIC T4
Switzerland (SEV)	EN 50014 & EN 50020	99,7 70466, 03	EEx ia IIC T4
UK (BASEEFA to CENELEC standards)	EN 50014 & EN 50020 EN 50039	Ex90C 2002 Ex99E2199	EEx ia IIC T4 EEx ia IIC T4 (systems)
USA (FM)	3610 entity 3611 non-incendive	*	Class I, II, III Div I, Gps A-G Class I, Div 2, Gps A-D

* Approvals pending

TO ORDER, specify:

Model	MTL643 field-mounting IS text display MTL644 panel-mounting IS text display
interface	MTL5051 (RS232 or RS422)
IS power supply	MTL5025
Mounting kits	PIP68 (pipe/post mounting for MTL643)
Sealing kit	IPK68 (for MTL644)

Literature INM643 user's manual



Text and graphics displays for hazardous areas

MTL646/647 DISPLAYS

Intrinsically safe text displays

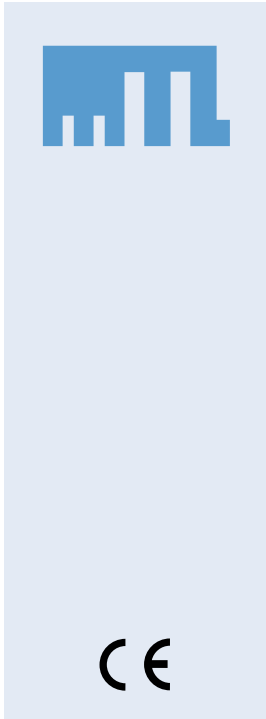

- ◆ IS display certified to ATEX
- ◆ High contrast LCD with backlight
- ◆ Communication from a safe area via a galvanic isolator
- ◆ Operator push-buttons or external switch inputs
- ◆ Two switch outputs
- ◆ IP65 front panel

The MTL646/647 Serial Text Displays are intrinsically safe instruments that can display text and simple graphics in a hazardous area. Having a number of push-buttons and two solid-state switched outputs, they provide a low cost operator interface ideal for simple machine and process control applications. In addition to new installations, the legacy protocol enables existing MTL643/644 display systems to be easily upgraded.

Data and power are normally supplied by a 2-wire serial data link from an MTL5051 isolator in the safe area. This isolator, which can power and communicate with up to two MTL646/647 serial text displays, has a bi-directional RS232 or RS422 safe area port. Alternatively, a 3 wire system may be used to communicate with up to four MTL646/647 text displays.

The high contrast LCD incorporates a green backlight that is powered by the serial data link. Brightness and contrast are adjustable enabling the display to be read in all lighting conditions from full sunlight to total darkness.

Six push-buttons on the front panel of the MTL646 (four on the MTL647) may be used for operator acknowledgments or controls. If larger industrial switches are required, these may be connected to the text display rear (MTL647-internal) terminals. When the remote switches are activated, the front panel push-buttons are disabled automatically.

Two isolated switch outputs, which can control certified hazardous area loads such as sounders, lamps and valves, are included.

The MTL646/647 text displays are normally controlled and interrogated by a safe area process computer or by a dedicated instrument such as a PLC or weighing system. The text displays may be used singly but up to four instruments can be multidropped on a hazardous area network. At a data rate of 9600 bps, the cable between the safe area galvanic isolator and the MTL646/647 text display may be up to 100m long. The protocol, which uses ASCII characters, enables text to be written anywhere on the screen in five different font sizes, together with lines, boxes and bargraphs. Simple bitmap graphics may be downloaded to the display and all characters can be reversed or flashed. Information can also be written to a hidden screen which may be displayed when required.

Five different operational modes are selectable, allowing the user to choose the appropriate level of communications security for each application. These range from immediate execution of a command with no message acknowledgement, to a 16 bit CRC. The communications speed, number of stop bits and polarity of the parity bit can also be defined.

The legacy protocol enables the MTL646 or MTL647 to replace an MTL643 or MTL644, in order to provide certification to ATEX and a display backlight. No software or galvanic isolator changes are required and the MTL646 will fit into the existing panel cut-out. If required, simple modifications to the driver software will allow the enhanced features of the MTL646/647 to be used.

SPECIFICATIONS

Location

Zone 0, 1 or 2

DISPLAY

Type

120 x 64 pixel liquid crystal.

Display Size

86.5mm x 45mm.

Backlight

Powered from serial link.

Characters

ASCII character set, 5 font sizes each with 4 computer definable soft characters.

Hidden screen

May be written to at any time and displayed when required.

Switch cable length

5m max.

OUTPUTS

Two software controlled switch outputs.

Contacts

Isolated single pole solid state switch (certified as simple apparatus).

R_{on} less than $5\Omega + 0.7V$

R_{off} greater than $1M\Omega$

I.S. parameters

$U_i = 28Vdc$, $I_i = 200mA$, $P_i = 0.85W$

DATA

Transmission Speed

0.3, 0.6, 1.2, 2.4, 4.8, 9.6 or 19.2k bps.*

Cable length between isolator(s) & MTL646/647

100m max at Baud rate of 9.6k bps*

*Depends upon configuration & type of cable - see instruction manual.

Format

1 or 2 stop bits; odd, even or no parity bit; 7 or 8 data bits.

Protocol

MTL646/647 or MTL643/644.

CONTROLS

Front panel

MTL646: 6 push-buttons which can be software interrogated.

MTL647: 4 push-buttons which can be software interrogated.

Each button function may be displayed on the screen. Buttons may be disabled.

External switches

Control may be transferred to six external switches; front panel buttons are inhibited.

ENVIRONMENTAL

Operating temp

-20°C to +60°C (certified for use at -40°C)

Humidity

To 95% @ 40°C

Enclosure

Front IP65

Rear IP20

MECHANICAL

Terminals

Removable with screw clamp for 0.5 to 1.5mm 2 cable.

Weight

MTL646 0.7kg

MTL647 1.6kg

ACCESSORIES

Tag number

Thermally printed strip on rear of instrument.

Programming guide

May be downloaded from <http://www.mtl-inst.com>

APPROVALS - MTL646

Country	UK	UK
(Authority)	(ITS to CENELEC standards & ATEX Directive)	(ITS to CENELEC standard)
Standard	EN 50020: 2002 EN 50014: 1997 EN 50284: 1999	EN 500 39: 1980
Certificate/ file no.	ITS03ATEX21172	Ex 03E21194 2-wire system Ex 03E21195 3-wire system Ex 03E21196 4-wire system
Approved for	Group II Category 1G EEx ia IIC T5	EEx ia IIC T5

APPROVALS - MTL647

Country	UK	UK
(Authority)	(ITS to CENELEC standards & ATEX Directive)	(ITS to CENELEC standard)
Standard	EN 50020: 2002 EN 50014: 1997 EN 50284: 1999	EN 500 39: 1980
Certificate/ file no.	ITS03ATEX21173	Ex 03E21194 2-wire system Ex 03E21195 3-wire system Ex 03E21196 4-wire system
Approved for	Group II Category 1G EEx ia IIC T5	EEx ia IIC T5

MTL646

DIMENSIONS

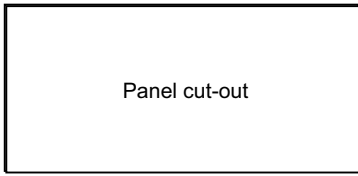

Recommended panel cut-out

DIN 43 700
138.0 +1.0/-0.0 x 68.0 +0.7/-0.0

To achieve an IP65 seal between the instrument and the panel
136.0 +0.5/-0.0 x 66.2 +0.5/-0.0
Four panel mounting clips must be used

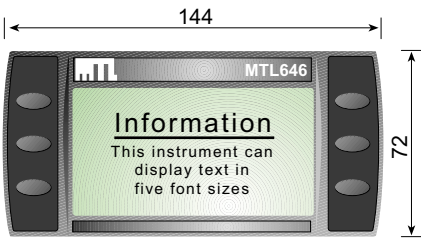
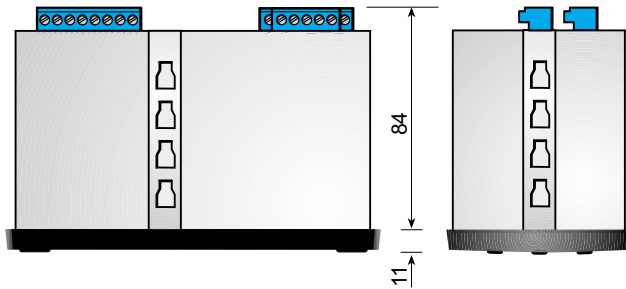

TERMINAL CONNECTIONS

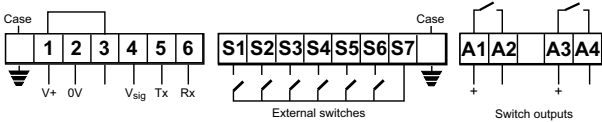

CONNECTIONS

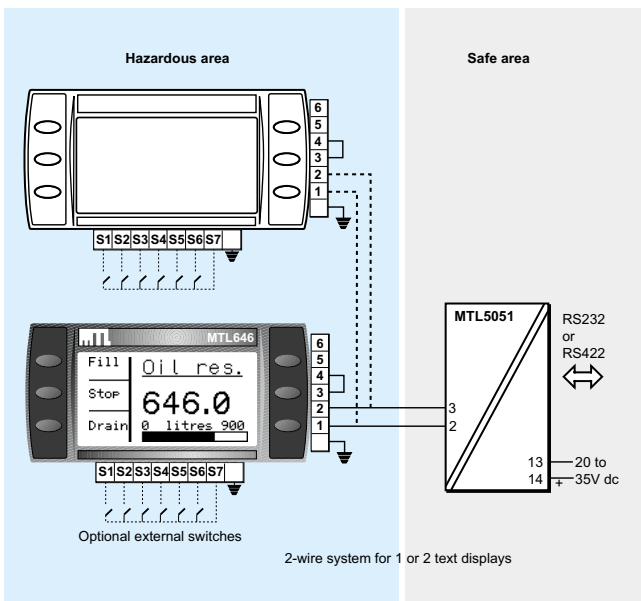

MTL647

DIMENSIONS

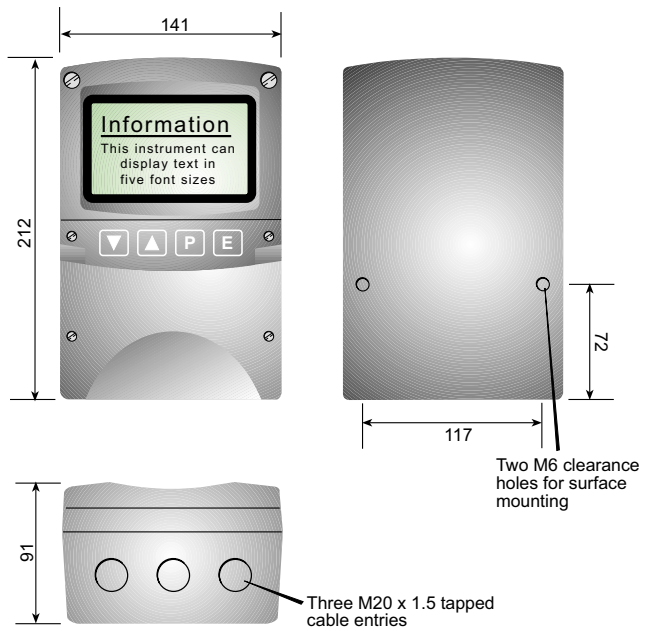

TERMINAL CONNECTIONS

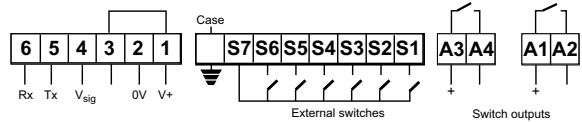

CONNECTIONS

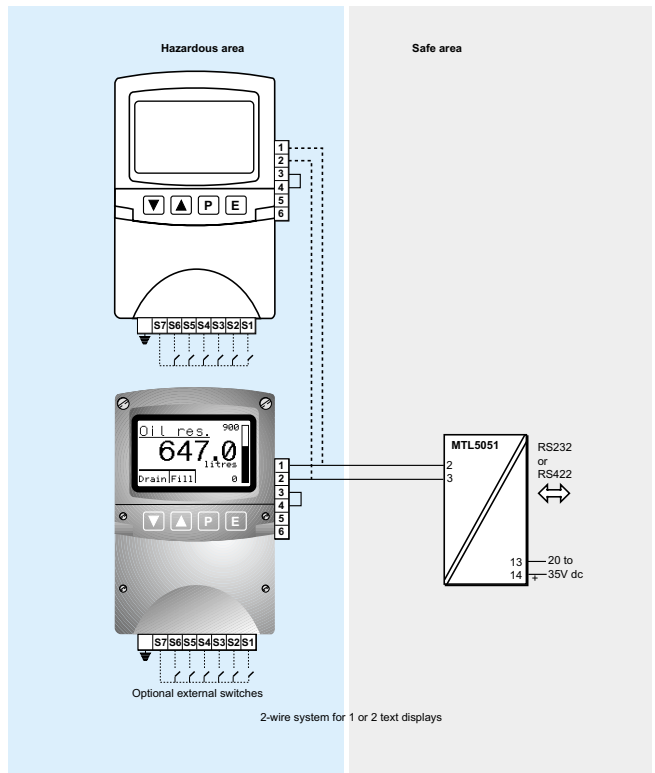

MTL661 and MTL662 IS INDICATOR loop powered



The MTL661 is a field, or MTL662 panel mounting, 4-20mA loop-powered IS indicator. This display provides an indication in hazardous-areas either loop powered or controlled by a signal from the safe-area.

Configuration is carried out by using the front panel switches (which may be password protected). Range units, upper and lower limits, decimal point positioning and number of digits displayed are all configured via the front panel.

SPECIFICATION

Unit location when installed to IS practice

Zone 0, IIC, T4 hazardous area
Div 1, Group A, hazardous location

Unit location when installed to 'non'incendive' practice

Div 2, Group A, Hazardous location

Display

Six 17mm digits (process value)
Eleven 8mm digits (process units & current)

Voltage requirements under all conditions

<1V, loop powered

Ambient Temperature

Operating: -20 to +70°C
Storage: -30 to +80°C

Humidity

5-99%RH

Input range

4-20mA

Over-range

200mA maximum without damage

Display Range

-.999999 to 999999 (Configurable)
Number of digits after decimal point configurable

Zero and span

Setting: anywhere in range

Scale direction

Normal or reverse: software selected.

Out of range indication

"----- RANGE ERROR" displayed between 3.5 - 3.75mA
"9999999 RANGE ERROR" displayed at current >22mA

Operating modes

Linear or square root extraction is software selectable.



Accuracy at 20°C

± 0.01mA

Effects of temperature on accuracy

Zero: ± 0.0025% of span /°C

Span: ± 0.01% of span /°C

Ripple rejection

<0.01mA error with 1mA peak to peak ripple at 50Hz

Electrical safety

The input circuit of the indicator is designed such that it does not influence the intrinsically safe circuit to which it is connected. (In the USA the application is covered by the entity concept.)

Input circuit (terminals 4 & 5) in type of explosion protection intrinsically safe EEx ia IIC, with the following parameters:
Ui=30V, li=200mA, Pi=1.2W, Ci=0nF, Li=0mH only for connection to a certified intrinsically safe circuit not exceeding these values.

Dimensions

W130 x H114 x D52mm (D44mm MTL662)
Panel mounting cutout W115mm H96mm

Enclosure

IP67 aluminium field mounting
ABS option available - MTL661-ABS

Cable glands

2 x M20 tapped holes provided

Weight

MTL661 - 825g

MTL662 - 425g

Approvals

EN50020:2002

Group II, Category 1GD EEx ia IIC T4 T_{amb} = -20°C to +70°C.
(The maximum temperature of the enclosure T100°C is referred to an ambient temperature of 70°C - Dust applications.)

