

mSA Series

Protects electronic equipment and systems against surges on signal and data cabling



- **Easy installation – ready boxed in IP65 weatherproof housing with cable glands**
- **Multi-stage hybrid protection circuitry – high surge absorption capability**
- **Single and dual pair versions available**
- **Range of voltage ratings covering all process related signals**
- **10 year product warranty**



The mSA Series prevents surges and transient overvoltages conducted through data and signal cabling from causing damage to electronic systems such as instrumentation control panels, telemetry outstations and fire and security alarm installations.

Isolated applications are particularly at risk, e.g. unmanned water monitoring stations, as they are regularly exposed to lightning activity and therefore suffer frequent damage. Telematic mSA Series surge protection devices increase system reliability, prevent costly damage to equipment and reduce maintenance costs at remote sites.

Sophisticated hybrid circuitry protects vulnerable equipment without affecting normal operation, passing ac or dc signals with little attenuation while diverting surge currents safely to earth and clamping output voltages to safe levels.

Modules with a comprehensive range of

voltage ratings (6V, 16V, 30V, 51V and 75V versions) cover all process related signals such as RTDs, THCs and 4-20mA loops. Single and dual pair versions allow installation flexibility and are ideal for 3 and 4-wire RTD applications.

These self-contained units provide a weatherproof barrier especially suitable for exposed locations. The whole circuit is assembled inside an IP65 (NEMA 12 and 13) enclosure which is ready fitted with cable glands and an external earth stud, so installation is very simple. Connections for the mSA Series are via screw-clamp terminals.

The mSA design incorporates test points to enable fast maintenance checks. Removable links enable the 'high' and 'low' energy sections to be tested independently.

The mSA Series
i s

also suitable for Telecom applications - private wire installations can be protected using the standard mSA range. Public Switched Telephone Networks (PSTNs) are served by the specifically designed mSAPN Series which utilises the same rugged enclosure as the mSA range. mSAPN devices are available with either single or dual line-pair protection networks, like the mSA units, and are supplied with IDC-type terminals. An IDC insertion tool is supplied for ease of convenience.

Data & Signal Protection

Specification

All figures typical at 25°C (77°F) unless otherwise stated

Maximum surge current

10kA (8/20µs waveform)

Nominal resistance per line

mSA's 43 ohms
mSAPN's 5 ohms

Ambient temperature limits

-40°C to +80°C - working
-40°F to +176°F - working

Humidity

5% to 95% RH (non-condensing)

Enclosure

Plastic ABS
IP65 (NEMA 12 and 13)
Ready fitted with cable glands

Connectors

mSA's screw-clamp terminals
mSAPN's IDC terminals

Terminals

mSA's 2.5mm² (12AWG)
mSAPN's IDC terminals (tool provided)

Mounting

via M5 external earth stud

Weight

220g (7.8oz) approx.

Dimensions

See figure 1

EMC compliance

To Generic Immunity Standards
BS EN 50082, part 2 for industrial environments

R&TTE compliance

BS EN 50082-2: 1995
BS EN 41003: 1999

LVD compliance (mSAPN)

BS EN 41003: 1999

Installation

Figure 2 shows the installation for a typical telemetry outstation. All cables entering the telemetry cabin should be fitted with surge protection devices (SPDs) to prevent lightning currents entering telemetry equipment. mSA30 devices can be used for 4-20mA applications whilst PSTN lines should be protected using the mSAPN.

Correct earthing is essential for optimum protection against lightning induced overvoltages. The units should be bonded to the incoming mains power supply using a short length, preferably less than 1 metre, of 2.5mm² or greater thickness cable.

Approvals

Model	Body	Certificate
mSA06 - mSA51	BT	NS/2190/2/F/450911
mSAPN	Oftel PTT ODTR	NS/G/1235/W/100025 NL 93040203 (The Netherlands) DOC 19/99 (Eire)

Note: Approvals now superseded by CE marking under the R&TTE Directive. See 'Specification' section for further information.

To order specify -

Model number as per specification table above

Note: In accordance with our policy of continuous improvement, Telematic reserves the right to change the product's specification without notice.

Model	Lines	Working voltage (V)	Rated load current (mA)	Maximum leakage current (µA)	Maximum continuous operating voltage (V)	Limiting voltage (V)	Bandwidth
mSA06/1	1 pair	5.5	70	1000	6	30	220kHz
mSA16/1	1 pair	13.5	180	5	16	40	380kHz
mSA30/1	1 pair	25.5	340	5	30	60	500kHz
mSA51/1	1 pair	43.5	400	5	51	100	580kHz
mSA75/1	1 pair	64	400	5	75	150	600kHz
mSA06/2	2 pairs	5.5	70	1000	6	30	220kHz
mSA16/2	2 pairs	13.5	180	5	16	40	380kHz
mSA30/2	2 pairs	25.5	340	5	30	60	500kHz
mSA51/2	2 pairs	43.5	400	5	51	100	580kHz
mSA75/2	2 pairs	64	400	5	75	150	600kHz
mSAPN/1	1 pair	180	N/A	10	200	250	10MHz
mSAPN/2	2 pairs	180	N/A	10	200	250	10MHz

Definitions of terminology used in table

1 Working voltage

Maximum voltage between lines or lines/earth for the specified leakage current

2 Maximum leakage current

Maximum current drawn by the SPD at the working voltage

3 Maximum continuous operating voltage

Maximum voltage that can be applied to the protected terminals without damage

4 Limiting voltage

Peak output voltage after injection of test impulse from 6kV/3kA combination waveform generator (often known as 'let-through' voltage)

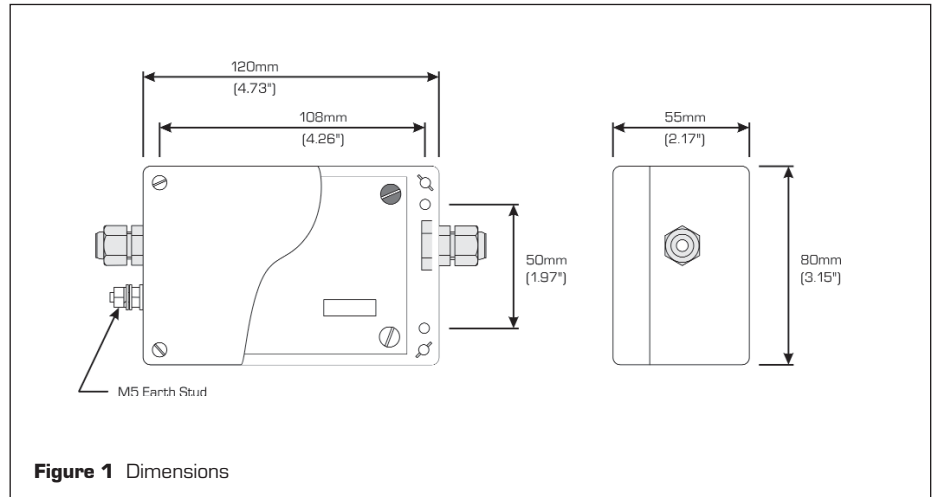

Figure 1 Dimensions

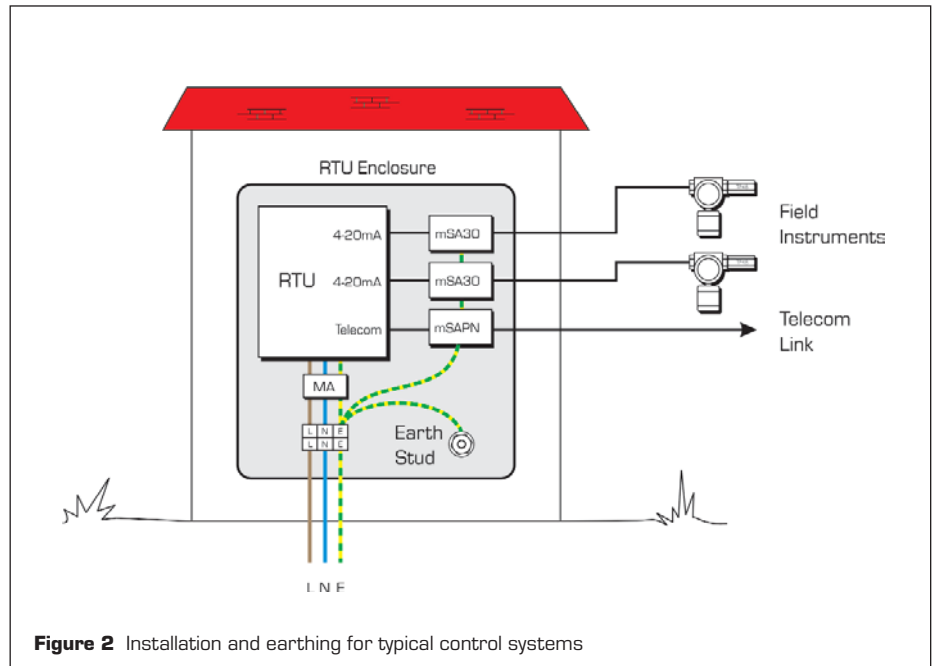

Figure 2 Installation and earthing for typical control systems

